

**Product Information P41****FOOD**

# Pressure Transmitter P41

**CLEANadapt****Application/Specified usage**

- Pressure measurement in pipes and tanks
- For process temperatures up to 250 °C (482 °F) with optional cooling section

**Application examples**

- Sanitary pressure monitoring for breweries, dairies and food & beverage production

**Hygienic design/Process connection**

- Hygienic process connection with CLEANadapt
- Versions compliant to 3-A Standard 74- available
- All wetted materials are FDA-conform
- Sensor completely made of stainless steel
- Complete overview of process connections: see order code
- The Anderson-Negele CLEANadapt system offers a flow-optimized, hygienic and easily sterilizable installation solution for sensors.

**Features**

- CIP/SIP cleaning up to 150 °C (302 °F) for max. 60 minutes
- Rapid response time of < 10 ms
- Vacuum-proof
- Easy to operate
- Electrical connection with M12 plug connection
- Available with relative or absolute measurement cell
- Built-in two-conductor measurement converter 4...20 mA

**Options/Accessories**

- Special pressure ranges, customer-specific upper range limit at factory
- 3.1 Material certificate

**Measuring principle of the pressure sensor**

This unit utilizes an internal piezoelectric transducer to convert the process measurement into a corresponding mV signal. The mV signal then passes through custom linearization and conditioning circuitry. The resulting signal is an industry standard 4...20 mA. This mA signal is factory set over the specified range of the unit.

With relative (gauge) pressure sensor the back of the transducer is vented to atmospheric pressure, i.e. this sensor measures the gauge pressure and/or vacuum relative to the atmospheric pressure. With absolute pressure sensor the back of the transducer is subject to full vacuum and then permanently sealed, i.e. this sensor measures pressure relative to an absolute vacuum.

**Communication**

**4...20 mA**
**P41**

Specification		
Pressure cells	relative, absolute [bar]	0.2 / 0.4 / 1.0 / 2.0 / 4.0 / 7.0 / 10.0 / 20.0 / 40.0
	relative, absolute [psi]	3 / 6 / 15 / 30 / 60 / 100 / 145 / 290 / 580
Electrical connection	Plug connection	M12 connector
	Supply voltage	10...30 V DC
Output		4...20 mA
Process connection	3-A compliant	1" / 1½" Tri-Clamp® 2" Tri-Clamp®
	Not 3-A compliant	G1/2" DIN 3852 (front flush mounting) G1" DIN 3852 (front flush mounting) CLEANadapt G1" Varivent type F, DN25 Varivent type N, DN40/50
Materials	Diaphragm	Stainless steel 1.4435 (AISI 316L)
	Housing	Stainless steel 1.4404 (AISI 316L)
	Connector	Stainless steel 1.4301 (AISI 304)
	Oil filling	FDA-approved oil, approval number 21CFR178.3570
Protection class		IP 69 K
Accuracy		±0.25% of upper range limit
Stability		±0,1%/year
Temperature ranges	Ambient	-40...85 °C (-40...185 °F)
	Process	-10...125 °C (14...257 °F)
	CIP/SIP cleaning	-10...250 °C (14...482 °F) as high-temperature version
	Storage	150 °C (302 °F) / max. 60 min, at t <sub>ambient</sub> 50 °C (122 °F) -40...100 °C (-40...212 °F)
Temperature drift		±0,1 % of upper range limit/10 K
Overpressure resistance	Pressure cell	Max. pressure
	0,2 bar (3 psi)	2 bar (30 psi)
	0,4 bar (6 psi)	2 bar (30 psi)
	1,0 bar (15 psi)	5 bar (72 psi)
	2,0 bar (30 psi)	10 bar (145 psi)
	4,0 bar (60 psi)	20 bar (290 psi)
	7,0 bar (100 psi)	40 bar (580 psi)
	10,0 bar (145 psi)	40 bar (580 psi)
	20,0 bar (290 psi)	80 bar (1160 psi)
	40,0 bar (580 psi)	100 bar (1450 psi)
Response time		< 10 ms
Weight	CLEANadapt G1"	450 g
	Tri-Clamp 1½"	250 g

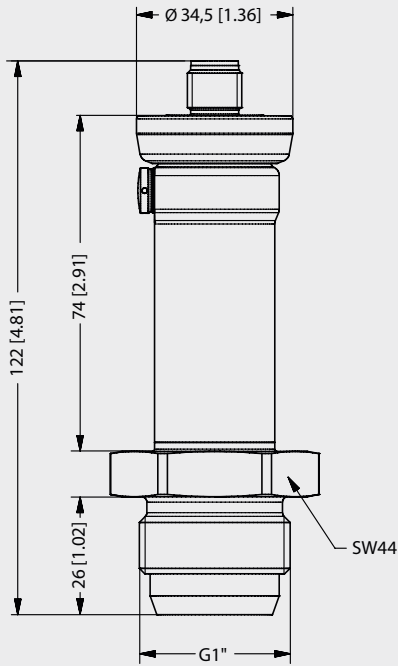
P41 | CLEANadapt G1" hygienic

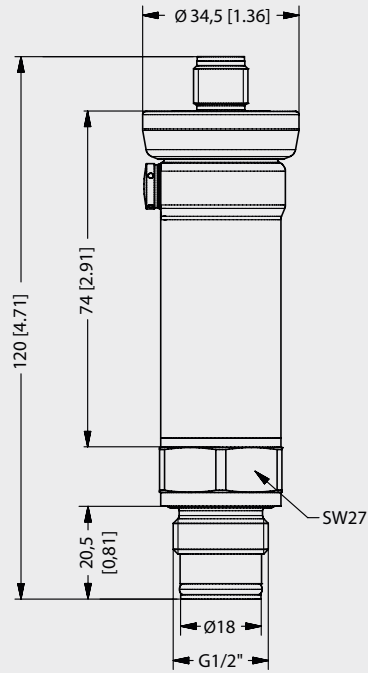

P41 | G1/2" DIN 3852



P41 | G1" DIN 3852

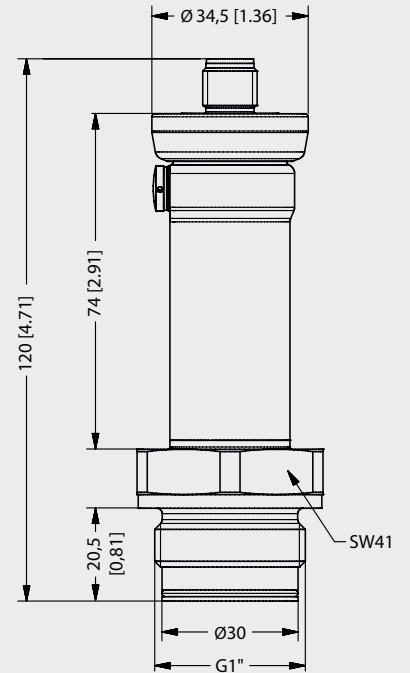

P41 | CLEANadapt Varivent

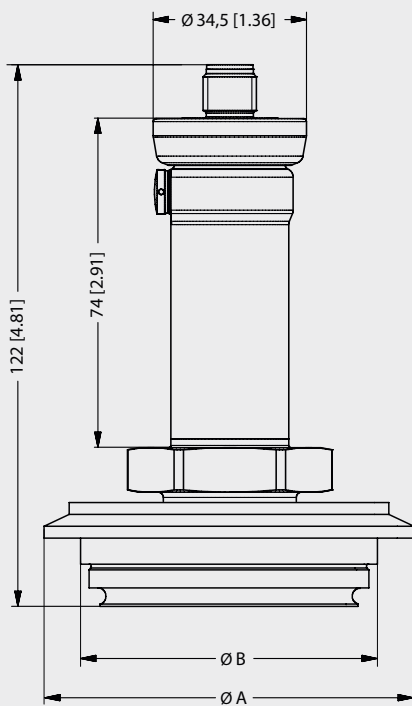

P41 | Tri-Clamp

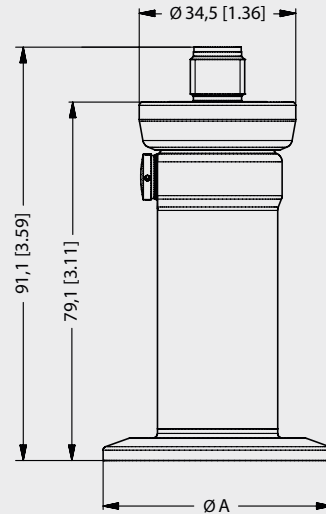

P41 | High-temperature version with cooling section

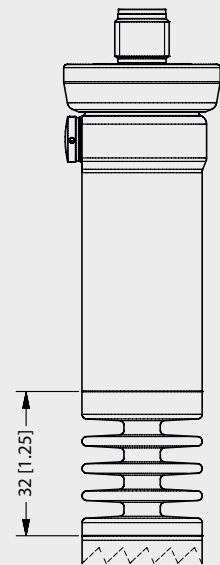

The cooling section extends the overall sensor length about 32 mm (1.25 inch).

Dimension table Varivent®

Type	Varivent® Type	Ø A [mm / inch]	Ø B [mm / inch]
V25	F	66.0 / 2.60	57.0 / 2.24
V40	N	84.0 / 3.31	75.0 / 2.95

Dimension table Tri-Clamp®

Type	Tri-Clamp® Type	Ø A [mm / inch]	Ø Diaphragm [mm / inch]
003	1" / 1½"	50.5 / 1.99	23.0 / 0.91
005	2"	64.0 / 2.52	45.0 / 1.77

**Startup**

- Connect the sensor with the supply voltage (10...30 V DC) -> see "Electrical connection" section.
- Note: In the factory setting, 0...100.0 % of the measurement range correspond to 4...20 mA at the current output.
- It is recommended to check the zero point every six months.
- Further maintenance work is not required.

**Electrical connection****Configuration M12-plug**

- 1: + power supply
- 2: - power supply 4...20 mA
- 3: not connected
- 4: not connected

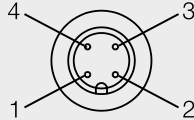
**Mechanical connection/Installation**

For G1" CLEANadapt only

- Attention: The maximum torque for mounting is 20 Nm!
- Use Negele CLEANadapt system for safe operation of measuring point.
- Use a welding mandril for correct installation of CLEANadapt weld-in-fittings. Please pay attention to the weld-in and installation details in the CLEANadapt product information.

**Conventional usage**

- Not suitable for applications in explosive areas.
- Not suitable for applications in security-relevant equipments (SIL).

**Note on 3-A Sanitary Standard 74-**

Information on installation according to 3-A standard is available on our website:  
[www.anderson-negele.com/3A74.pdf](http://www.anderson-negele.com/3A74.pdf)

Click on the PDF icon to download the document.

**Cleaning and maintenance**

- Don't use sharp items or aggressive detergents for cleaning.
- In case of using pressure washers, don't point nozzle directly to electrical connection!

**Reshipment**

- Sensors and process connection must be clean and must not be contaminated with hazardous media and/or heatconductive paste. Note the cleaning information!
- To avoid damage of the equipment, use suitable transport packaging only.

**Transport/Storage**

- No outdoor storage
- Store in an area that is dry and dust-free
- Do not expose to corrosive media
- Protect against solar radiation
- Avoiding mechanical shock and vibration
- Storage temperature -10...85 °C (14...185 °F)
- Relative humidity max. 80 %

**Standards and guidelines**

- Compliance with the applicable regulations and directives is mandatory.

**Disposal**

- Electrical devices should not be disposed of with household trash. They must be recycled in accordance with national laws and regulations.
- Take the device directly to a specialized recycling company and do not use municipal collection points.

**Note on CE**

- Applicable directives:  
Electromagnetic Compatibility Directive 2014/30/EU
- Compliance with the applicable EU directives is identified by the CE label on the product.
- The operating company is responsible for complying with the guidelines applicable to the entire installation.

**Accessories****PVC-cable with M12-connection, 1.4305 (AISI 303), IP 69 K, unshielded**

M12-PVC / 4-5 m	PVC-cable 4-pin, length 5 m
M12-PVC / 4-10 m	PVC-cable 4-pin, length 10 m
M12-PVC / 4-25 m	PVC-cable 4-pin, length 25 m

**PVC-cable with M12-connection, brass nickel-plated, IP 67, shielded**

M12-PVC / 4G-5 m	PVC-cable 4-pin, length 5 m
M12-PVC / 4G-10 m	PVC-cable 4-pin, length 10 m
M12-PVC / 4G-25 m	PVC-cable 4-pin, length 25 m

**CERT / 2.2 / P41**

factory certificate 2.2 acc. to EN10204  
(only product contacting surface)



**CAL / P41**

factory calibration certificate with  
3 calibration points (0 %, 50 %, 100 %)

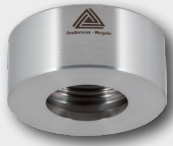

**CAL / P41 / MP**

factory calibration certificate with  
5 calibration points  
(0 %, 25 %, 50 %, 75 %, 100 %)

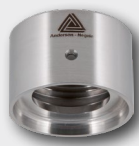
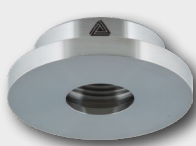
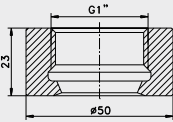
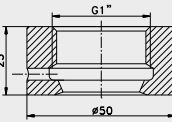
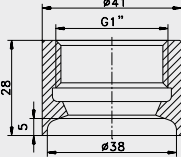
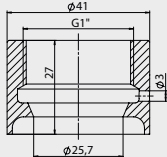

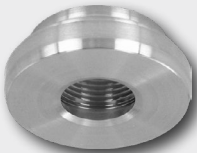
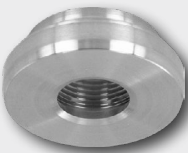
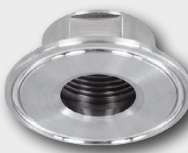

**PVC-cable with M12-connection**

Weld-in sleeves					
<b>CLEANadapt G1"</b>					
					
	<b>Cylindrical sleeve</b>	<b>Cylindrical sleeve with leakage hole</b>	<b>Cylindrical sleeve with welded collar</b>	<b>Cylindrical sleeve with welded collar and leakage hole</b>	<b>Collar sleeve</b>
	EMZ-352 * (for thick/thin containers)	EMZ-351 * (for container with leak monitor)	EMS-352 * (for installation on pulled-out pipes)	EMS-351 * (for installation on pulled-out pipes)	EMK-352 * (for thick-walled tanks)

\* Deliverable with 1.4435 (AISI 316L) material and 3.1 inspection certificate on request.

Adapters for prevalent process connections					
<b>CLEANadapt G1"</b>					
<b>Nominal size</b>	<b>Dairy flange (DIN 11851)</b>	<b>DRD (optionally deliverable pressure ring)</b>	<b>Tri-Clamp with leakage hole</b>	<b>APV-Inline</b>	<b>BioControl</b>
<b>DN25</b> <b>1"</b>	AMK-352/DN25	AMK-352/50 (only one size)	AMC-351/DN25	-	-
<b>DN32</b>	AMK-352/DN32		AMC-351/DN25	-	-
<b>DN40</b> <b>1½"</b>	AMK-352/DN40		AMC-351/DN25	AMA-352 From DN40 to DN100	AMB-50/1" and AMB-65/1"  From DN40 to DN100
<b>DN50</b> <b>2"</b>	AMK-352/DN50		AMC-351/DN50		
<b>DN65</b> <b>2½"</b>	AMK-352/DN65		AMC-351/2½"		
<b>DN65</b>	AMK-352/DN65		AMC-351/DN65		
<b>DN80</b>	-		AMC-351/DN65		
<b>DN80</b>	AMK-352/DN80		AMC-351/DN80		
<b>DN100</b>	AMK-352/DN100	AMC-351/DN100			

## Adapter sleeves G1" to other thread sizes and accessories

CLEANadapt G1"					
	<b>Adapter</b>	<b>Adapter</b>	<b>Adapter</b>	<b>Blind plug</b>	
	AMG-352 G1,5" (Standard thread G1½" to CLEAN-adapt G1")	AMG-352 G1,75" (Standard thread G1¾" to CLEAN-adapt G1")	AMG-352 G2" (Standard thread G2" to CLEAN-adapt G1")	BST-350 (For closing a CLEANadapt G1" measuring point)	

## Dimensions EHG-DIN2-... / 1"

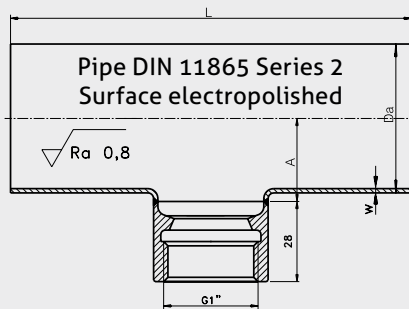

## EHG-DIN2-... / 1"



## Dimensions table EHG-DIN2-... / 1"

Type	DN	L [mm / inch]	A [mm / inch]	Da x W [mm / inch]
EHG-DIN2-40 / 1"	40	120 / 4.72	22.0 / 0.87	41 x 1.5 / 1.61 x 0.06
EHG-DIN2-50 / 1"	50	140 / 5.51	29.0 / 1.14	53 x 1.5 / 2.09 x 0.06
EHG-DIN2-65 / 1"	65	160 / 6.30	38.0 / 1.50	70 x 2.0 / 2.76 x 0.08
EHG-DIN2-80 / 1"	80	180 / 7.09	46.0 / 1.81	85 x 2.0 / 3.35 x 0.08
EHG-DIN2-100 / 1"	100	200 / 7.87	55.0 / 2.17	104 x 2.0 / 4.09 x 0.08
EHG-DIN2-125 / 1"	125	375 / 14.76	69.5 / 2.74	129 x 2.0 / 5.08 x 0.08
EHG-DIN2-150 / 1"	150	450 / 17.72	82.0 / 3.23	154 x 2.0 / 6.06 x 0.08

## Order Code

P41 Pressure sensor

## Measuring range of pressure cell

- 1 0.2 bar (3 psi)
- 2 0.4 bar (6 psi)
- 3 1.0 bar (15 psi)
- 4 2.0 bar (30 psi)
- 5 4.0 bar (60 psi)
- 6 7.0 bar (100 psi)
- 7 10 bar (145 psi)
- 8 20 bar (290 psi)
- 9 40 bar (580 psi)

## Pressure measurement

- A Absolute (absolute measurement, min. 0,4 bar / 6 psi)
- G Gauge (relative measurement without vacuum)
- C Compound (relative measurement including vacuum)

## Process connection (Ⓐ: 3-A compliant)

- 195 G1/2" DIN 3852 (front flush with O-ring)
- 201 G1" DIN 3852 (front flush with O-ring)
- 182 CLEANadapt G1" hygienic
- 003 Tri-Clamp 1" / 1½" Ⓐ
- 005 Tri-Clamp 2" Ⓐ
- V25 Varivent Typ F, DN25 (adaption by means of CLEANadapt)
- V40 Varivent Typ N, DN40/50 Ⓐ

## Sealing material (only selectable for process connections 195 and 201)

- X No seal
- A EPDM (< 125 °C (257 °F))
- B FKM (< 200 °C (392 °F))
- C FFKM (> 200 °C (392 °F))

## Capillary fill

- 6 FDA approved oil

## Sensor Version Process Temperature

- X Standard temperature (max. 125 °C (257 °F))
- H High temperature version (max. 250 °C (482 °F))

## Physical unit

- B bar
- P psi

## Upper range limit

- 0,0 Unlimited measuring range of pressure cell
- [x,x] Factory setting as per customer requirement

## Material certificate

- X No certificate
- Z 3.1 Material certificate

## Configuration

- 0 Fixed value

P41 1 A 182 X 6 X B 0,2 X 0