

DURA-FLO

INVERTED BUCKET STEAM TRAPS

Pressures To 250 PSIG (17.2 barg)
Temperatures to 450°F (232°C)

Hardened Stainless Steel Valve and Seat - Long life and maximum corrosion resistance.

Stainless Steel Bucket - Long lasting, rugged and naturally resistant to water hammer.

Inexpensive - Low maintenance and initial cost.

Repairable in-line - All working parts lift out of top of trap.

Cast Iron Body - Durable heavy wall construction provides years of reliable service.

Suitable for Wide Variety of Loads/Applications - Horizontal and vertical models in thirteen body sizes.

Resists Dirt and Scale - Valve and seats positioned at top of traps and internal stainless strainer available on most horizontal models ensure long service.

Applications

- Steam Lines
- Process Equipment
- Steam Cookers
- Steam Heated Vats
- Pressing Machinery
- Unit Heaters
- Oil Preheaters
- Converters
- Coils
- Rotating Drum

Options

- Repair Kits

Operation

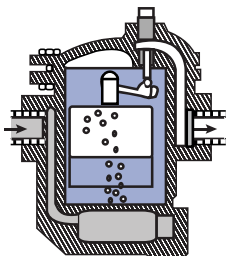

Trap Closed

After trap is installed and primed, steam entering the trap collects in the top of the bucket, floating the bucket and forcing the valve into its seat.

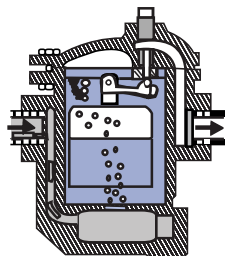

Trap Begins to Open

As condensate begins to flow into the trap, steam and air are forced from the bucket. This causes the bucket to begin losing buoyancy, tending to pull the valve from its seat.

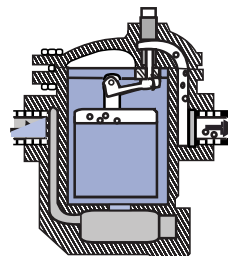

Trap Discharges

When enough condensate has entered the trap, displacing the steam and air, the bucket drops, pulling the valve from the seat and allowing condensate and air to discharge.

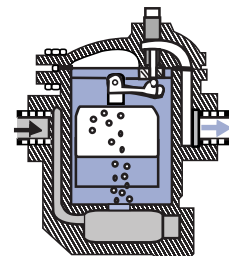

Trap Closes

As the flow of condensate stops, steam enters the trap and refloats the bucket, forcing the valve into its seat. The cycle then repeats as more condensate reaches the trap.



MODELS*

- 80S—Low capacity horizontal w/integral strainer
- 81S—Medium low capacity horizontal w/integral strainer
- 82S—Medium capacity horizontal w/integral strainer
- 83S—Medium high capacity horizontal w/integral strainer
- 84—High capacity horizontal
- 85—Super high capacity horizontal
- 86—Ultra high capacity horizontal
- 21—Medium low capacity vertical
- 22—Medium capacity vertical
- 23—Medium high capacity vertical
- 24—High capacity vertical
- 25—Super high capacity vertical
- 26—Ultra high capacity vertical

Canadian Registration # OE 0591.1C

Installation Tip: Always install STV Test & Block Valve as part of trap station SEE PAGE 118

Installation Tip: Add Uniflex Pipe Coupling for ease of maintenance SEE PAGE 102

DURA-FLO

INVERTED BUCKET STEAM TRAP

Pressures To 250 PSIG
Temperatures to 450°F

Applications

- Steam Lines
- Unit Heaters
- Process Equipment
- Oil Preheaters
- Steam Cookers
- Converters
- Steam Heated Vats
- Coils
- Pressing Machinery
- Rotating Drum

Easy to Maintain

Working parts lift out with top for quick inspection and maintenance.

Resists Corrosion

Stainless steel bucket provides maximum service life with minimum deterioration.

Minimizes Effects of Water Hammer

Open bucket design avoids collapse typical of sealed floats.

Suitable for Wide Variety of Loads/Applications

Horizontal and vertical models in thirteen body sizes are one of the most comprehensive inverted bucket trap lines available.

Withstands Severe Conditions
Heavy wall cast iron cover and body provide many years of trouble free service.

Smooth Action and Tight Shutoff

Stainless steel linkage, valve and seats are precision manufactured to ensure optimal performance.

Ideal for "Dirty" Systems

Valve and seat located at top of trap and stainless steel strainers available on most horizontal models ensure long service

Maximum Compatibility with Existing Installations

Pressure change assemblies are interchangeable with Armstrong which guarantees maximum flexibility when stocking repair parts.



DURA-FLO

INVERTED BUCKET STEAM TRAPS

SPECIFICATION

Furnish and install as shown on the plans, inverted bucket traps capable of discharging condensate, air and other noncondensable gases without loss of steam. These traps shall have a heavy cast iron body, hardened stainless steel valve and seat, all stainless steel linkage and bucket, and an asbestos free fiber cover gasket.

Dimensions					
Trap	End Connections	Inches (mm)			Weight Lbs (kg)
		A	B	C	
80S	½, ¾	5 ¹ / ₁₆ (129)	2 ¹ / ₁₆ (69)	3 ¹ / ₂ (89)	7 (3.2)
81S	½, ¾, 1	5 ¹ / ₁₆ (129)	2 ¹ / ₁₆ (69)	4 ⁷ / ₁₆ (113)	8 (3.6)
82S	½, ¾	7 (178)	3 ⁷ / ₈ (98)	5 ¹ / ₁₆ (138)	22 (10.0)
83S	¾, 1	8 ⁷ / ₈ (206)	5 (127)	7 ⁷ / ₈ (194)	32 (14.5)
84	1, 1 ¹ / ₄	9 (229)	5 ³ / ₄ (146)	7 ¹ / ₁₆ (199)	47 (21.3)
85	1 ¹ / ₂ , 2	10 ¹ / ₄ (260)	8 (203)	8 ³ / ₈ (213)	74 (33.6)
86	2, 2 ¹ / ₂	13 (330)	9 ³ / ₄ (248)	11 (279)	140 (63.5)
21	½	6 ³ / ₈ (162)	4 ¹ / ₄ (108)	—	6.5 (2.9)
22	½, ¾	8 (203)	5 ⁵ / ₈ (143)	—	16 (7.3)
23	¾, 1	10 ¹ / ₂ (267)	6 ⁷ / ₈ (175)	—	28 (12.7)
24	1, 1 ¹ / ₄	12 ¹ / ₂ (318)	7 ¹ / ₂ (190)	—	35 (15.9)
25	1, 1 ¹ / ₂	14 ³ / ₈ (365)	9 ¹ / ₁₆ (230)	—	60 (27.2)
26	½, 2	16 ¹ / ₁₆ (424)	10 ¹ / ₄ (260)	—	90 (40.8)

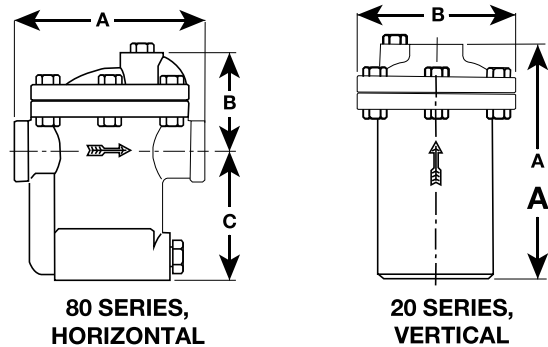

Connections: ½"– 2" NPT

Maximum operating conditions

PMO: Max. Operating Pressure	see orifice selection
TMO: Max. Operating Temperature	saturated at pressure
PMA: Max. Allowable Pressure	250 psig (17.2 barg)
TMA: Max. Allowable Temperature	450°F (232°C)

Materials of construction

Body & Cover	Cast Iron ASTM-A-126/A48
Bucket & Linkage	Stainless Steel
Valve & Seat	Hardened Chrome Steel
Standpipe	Steel Pipe
Cover Gasket	Asbestos Free Fiber

DURA-FLO

CAPACITY TABLES

Trap	Orifice		0.50 (.034)	1 (.069)	5 (.345)	10 (.690)	15 (1.03)	20 (1.38)	25 (1.72)	30 (2.07)	40 (2.76)	60 (4.14)	70 (4.83)	80 (5.52)	100 (6.90)	125 (8.62)	130 (8.97)	150 (10.3)	180 (12.4)	200 (13.8)	225 (15.5)	250 (17.2)	
	Size	Max ΔP																					
80S	3/16	20	200	270	450	560	640	690															
	1/8	80	80	110	200	300	360	420	460	500	540	620	660	690									
	7/64	125	-	55	90	145	195	260	305	345	400	485	525	565	640	680							
	3/32	150	-	-	70	110	150	200	240	270	310	380	410	440	480	540	545	570					
81S & 21	1/4	15	300	450	830	950	1060																
	3/16	30	190	300	540	670	770	880	950	1000													
	5/32	70	100	165	180	430	495	585	655	710	770	900	950										
	1/8	125	70	130	220	340	390	460	515	560	610	710	760	800	860	950							
	7/64	200	-	65	150	230	275	335	375	405	455	545	580	610	665	735	780	810	850	860			
3/32	250	-	-	100	150	190	240	270	290	340	420	450	470	520	575	585	620	670	700	730	760		
82S & 22	5/16	15	570	850	1600	1900	2100																
	1/4	30	350	500	950	1380	1630	1800	1900	2050													
	3/16	70	250	420	785	950	1120	1260	1395	1500	1700	2000	2200										
	5/32	125	180	300	560	680	800	900	995	1070	1220	1440	1550	1650	1800	2000							
	1/8	200	100	180	325	465	505	575	650	710	805	980	1050	1105	1225	1375	1410	1500	1560	1600			
7/64	250	75	130	240	340	370	420	480	520	590	720	770	810	900	1010	1020	1100	1170	1230	1280	1300		
83S & 23	1/2	15	1410	1880	2900	3500	3900																
	3/8	30	990	1400	2300	2700	3300	3500	3800	4000													
	5/16	60	600	940	1730	2045	2510	2825	2995	3135	3800	4400											
	9/32	80	510	735	1350	1595	1960	2205	2340	2450	2880	3490	3800	4000									
	1/4	125	385	600	1100	1300	1600	1800	1910	2000	2350	2850	3100	3300	3600	3900							
	7/32	180	300	490	860	1165	1350	1595	1865	2085	2205	2510	2695	2820	3065	3185	3300	3500	3700				
3/16	250	255	400	700	950	1100	1300	1520	1700	1800	2050	2200	2300	2500	2600	2700	2800	3020	3200	3400	3500		
84 & 24	5/8	15	2160	2900	4800	5800	6500																
	1/2	30	1450	2250	3700	4750	5200	6000	6500	6800													
	3/8	60	1050	1750	2950	3550	4000	4700	5000	5400	5800	6800											
	11/32	80	800	1560	2500	2900	3200	3500	4000	4400	4850	5750	6000	6400									
	5/16	125	660	1200	1950	2450	2750	3100	3250	3500	4000	4800	5250	5600	6200	6700							
	9/32	180	550	950	1500	1900	2200	2350	2700	2900	3250	3800	4250	4500	4800	5500	5600	5700	6000				
1/4	250	350	580	1000	1250	1450	1800	2000	2200	2600	3150	3350	3500	3800	4300	4450	4700	5000	5300	5500	5700		
85 & 25	3/4	15	3100	4160	7600	9000	10000																
	9/16	30	1800	2900	5200	6400	7700	8500	9200	9800													
	7/16	60	1400	2200	3800	5000	6000	6600	7100	7600	8300	9500											
	3/8	100	1100	1700	3000	3600	4500	5200	5800	6100	7000	8500	9200	9700	10400								
	11/32	130	900	1500	2600	3200	3900	4500	5000	5400	6200	7500	8050	8500	9600	10900	11000						
	5/16	180	750	1200	2100	2600	3200	3700	4100	4500	5400	6600	7000	7257	8118	8979	9040.5	9500	10000				
	9/32	225	600	970	1700	2100	2600	2950	3300	3600	4500	5400	5700	5900	6600	7300	7350	7850	8400	9200	9800		
1/4	250	400	700	1200	1500	1900	2100	2400	2600	3200	3800	4000	4150	4600	5100	5150	5500	5950	6350	6650	7000		
86 & 26	1-1/16	15	6240	8400	14500	17300	19200																
	7/8	25	4100	5490	10000	12930	15620	18500	20000														
	3/4	40	2900	4500	8200	10600	12800	15000	16700	18000	20000												
	5/8	60	2100	3500	6900	8700	10600	12100	13300	14250	16300	19800											
	9/16	80	1900	3095	6000	7600	9300	10600	11700	12500	14300	17300	18300	19000									
	1/2	125	1600	2600	5000	6400	7800	8900	9800	10500	12000	14500	15400	16300	18000	20000							
	7/16	180	1400	2210	4180	5530	6640	7500	8490	9230	10450	12420	13300	14150	15750	17400	17900	18500	20000				
3/8	250	1000	1800	3400	4500	5400	6100	6900	7500	8500	10100	10800	11500	12800	14200	14300	15600	16900	17500	18500	19000		

For Kg/Hr Multiply by .454

DURA-FLO INVERTED BUCKET STEAM TRAPS PCA REPAIR KITS

Quick, easy and economical

Simplifies and standardizes inventory

All stainless steel corrosion resistant internal parts

Hardened stainless steel condensate valves and seats for extra long life

MODELS

- **80S**—Orifice ratings 20, 80, 125, 150
- **81S & 21**—Orifice ratings 15, 30, 70, 125, 200, 250
- **82S & 22**—Orifice ratings 15, 30, 70, 125, 200, 250
- **83S & 23**—Orifice ratings 15, 30, 60, 80, 125, 180, 250
- **84 & 24**—Orifice ratings 15, 30, 60, 80, 125, 180, 250
- **85 & 25**—Orifice ratings 15, 30, 60, 100, 130, 180, 225, 250

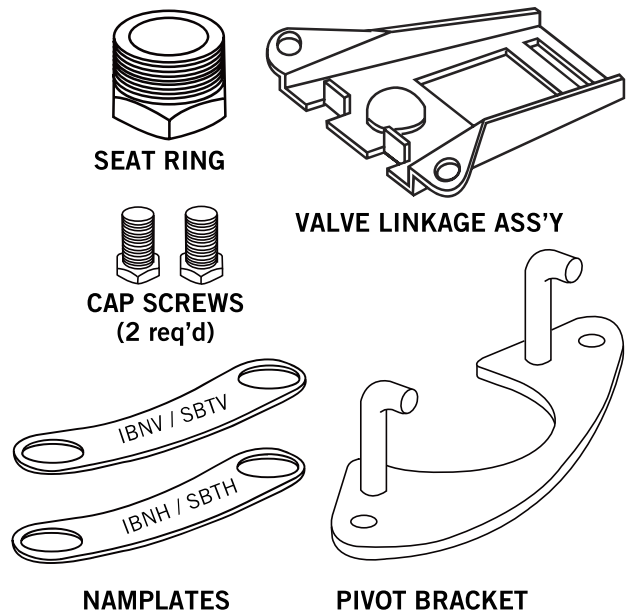

Supplied in a labeled, clear plastic bag.

FTN SERIES FLOAT & THERMOSTATIC STEAM TRAPS REPAIR KITS

High quality replacement kits

Rebuild existing F & T Traps far more economically than replacement

Quick, easy and economical

Simplifies and standardizes inventory

All stainless steel corrosion resistant internal parts

Hardened stainless steel condensate valves and seats for extra long life

Repairs other leading manufacturers' F & T Traps

MODELS

- **FTN-15** available in ¾", 1", 1¼", 1½" and 2"
- **FTN-30** available in ¾", 1", 1¼", 1½" and 2"
- **FTN-75** available in ¾", 1", 1¼", 1½" and 2"
- **FTN-125** available in ¾", 1", 1¼", 1½" and 2"

All ¾" and 1" kits as well as 1¼" FTN-15 and FTN-30 kits supplied with cover assembly.

All 1¼" FTN-75 and FTN-125 kits as well as all 1½" and 2" kits supplied as mechanism complete.

See Capacity Charts on page 37

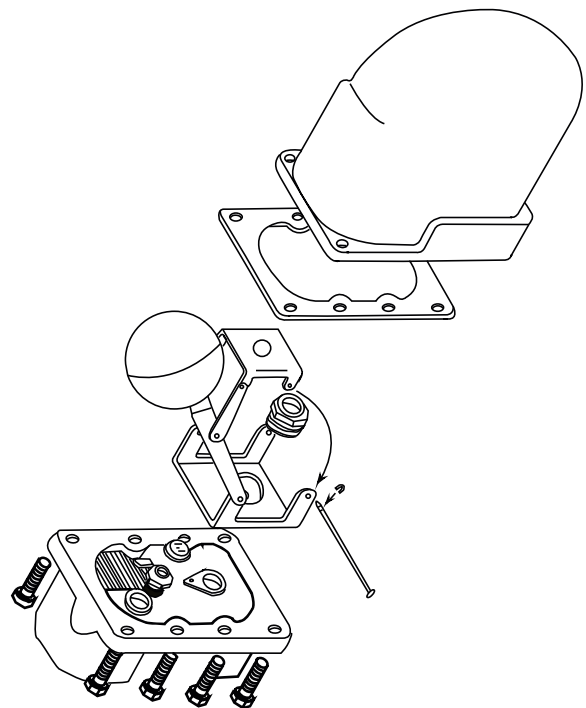

Consult factory for latest crossover fitments.