

Applications

- Collection of condensate
- Where electrical service is unavailable
- Submerged or remote sumps and manholes
- Hazardous fluids and process fluids
- Low pressure and vacuum systems
- High back pressure systems
- High capacity process applications

Condensate Commander Pump

Pressures to 250 PSIG (17.2 barg)
Temperatures to 650°F (343°C)

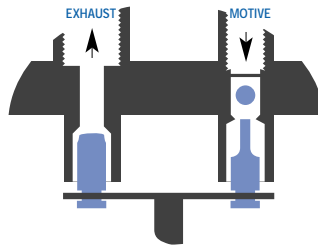

Inlet Supply and Vent Valves

Lapped valves and seats for tight shutoff

Stainless steel construction resists corrosion

Floating ball design and hardened sealing surface of supply valve provide long service life

Floating disk and ball valves feature an infinite number of seating surfaces

Self centering design assures reliable performance



Unique Patented Single Spring Mechanism

Eliminates pump breakdown due to spring failure

Snap acting mechanism actuates the valve

Heavy duty spring operating in compression carries lifetime warranty

Unaffected by turbulence

Stainless steel construction maximizes reliability and service life

Valve and linkage positioning above condensate level minimizes corrosion



Cycle Counter

accurately depicts number of cycles and assists in maintenance scheduling

Retrofit Mechanism Available

Head assembly fits many manufacturer's tanks

ASME Code Stamped Tank

Fabricated steel tank is standard on most models

Warrantied 3 Years or One Million Cycles

Longest warranty in the industry

CONDENSATE RECOVERY

NICHOLSON's broad range of Commander Series Pressure Actuated Pumps are recognized for their quality, durability and versatility. Skid systems, fabricated to meet customer requirements, are a value added specialty that differentiate **NICHOLSON**'s products from the competitors.



CONDENSATE COMMANDER PUMP

**Pressures To 250 PSIG (17.2 barg)
Temperatures to 650°F (343°C)**

No Electricity Needed

- Uses pressurized gas or steam as the pumping force.
- Preferable for remote or hazardous locations.

Lifetime Warranty on Spring

- Single spring mechanism operates in compression only to assure long service life
- Stainless steel snap action mechanism in continuous compression offers superior performance.

Rugged Mechanism

- Unaffected by turbulence.
- No adjustments or maintenance necessary.

Superior Valve Technology

- Supply and exhaust valves are lapped for tight shutoff.
- Self centering design assures reliable performance.
- Unique floating ball design and hardened sealing surface of the supply valve provide long service life.

Suitable for a Wide Variety of Liquids

- Condensate from steam systems.
- High back pressure, low pressure and vacuum systems.
- Ideal in a sump or other submersible applications.
- Suitable for acids and other process fluids that may be incompatible with conventional pumps.

Warrantied 3 Years or One Million Cycles

- Longest warranty in the industry.

ASME Code Stamped Tank

- Fabricated steel tank is standard on most models.

Retrofit Mechanism Available

- Head assembly can fit other manufacturer's tanks.

Required suction head is minimal

- Optimal performance achieved at only 12 inches.

APPLICATIONS

Collection of Condensate

- Remote Locations such as tank farms
- Low pressure and vacuum systems
- Condensate systems with high back pressure
- High capacity process applications such as heat exchangers

Electrical Service is Unavailable or Prohibited

- Remote locations
- Hazardous locations

Submerged Areas

- Sumps or low lying areas
- Manholes

Hazardous Fluids

- Process fluids that may be difficult for conventional electric pump technology to handle

OPTIONS

- Glass Water Gage
- Cycle Counter
- Bronze or Stainless Steel Check Valves
- Insulating Jacket
- Supply Pressure Regulator
- Stainless Steel Tanks
- High Temperature
- High Pressure

OPERATION

The vent valve is open, the pressure supply valve is closed and the float is positioned in the lower part of the tank as the condensate or other liquid enters the tank through the inlet check valve. As the tank fills with liquid, the float rises to the point where the spring mechanism snaps past the center position. The compressed spring instantly closes the vent valve and opens the pressure supply. This allows

pressure into the tank which forces the liquid through the outlet check valve.

As the liquid level falls, the float lowers to the point where the spring mechanism snaps past the center position which immediately closes the pressure supply valve and opens the vent valve. The pressure in the tank decreases, allowing liquid to flow through the inlet check valve, repeating the cycle.

MODELS

- **Classic**-Standard capacity, vertical tank
- **Big Boy**-Super capacity, horizontal tank
- **Horizontal**-Standard capacity, high pressure, horizontal tank
- **Little Boy**-Reduced capacity, vertical tank
- **Skid**-Standard or custom multiplex configurations

CONDENSATE COMMANDER CLASSIC PUMP

SPECIFICATION

Pump shall be a pressure vessel drainer operated by steam, compressed air or other pressurized gas to 200 psig. Body shall be fabricated steel ASME code to 200 psi. Pump mechanism shall be all stainless steel without external packing or seals. Mechanism shall employ one spring operating in continuous compression. Spring shall be warranted for the life of the unit. When required, unit shall be equipped with an external cycle counter, sight glass and insulating jacket.

MAXIMUM OPERATING CONDITIONS

PMO: Max. Operating Pressure	200 psig	(13.8 barg)
TMO: Max. Operating Temperature	400°F	(204°C)
PMA: Max. Allowable Pressure	200 psig	(13.8 barg)
TMA: Max. Allowable Temperature	400°F	(204°C)

With optional Temperature/Pressure upgrades:

PMO: Max. Operating Pressure	250 psig	(17.2 barg)
TMO: Max. Operating Temperature	650°F	(343°C)
PMA: Max. Allowable Pressure	250 psig	(17.2 barg)
TMA: Max. Allowable Temperature	650°F	(343°C)

MATERIALS OF CONSTRUCTION

Tank Weldment	Steel
Trip Mechanism w/Flange	DI/Stl/SS
Gasket	Graphite
Bolt, Hex Head	Steel
Eye Bolt	Steel
Nut	Steel
Nameplate	Aluminum
Drive Screw	Steel
Pipe Plug, 1/2" NPT	Steel
Water Level Gage	Bronze
Inlet Reducer	M. Iron
Inlet Nipple	Steel
Inlet Check Valve	Bronze/Stainless Steel
Outlet Reducer	M. Iron
Outlet Nipple	Steel
Outlet Check Valve	Bronze/Stainless Steel

OPERATING CHARACTERISTICS

Pump Discharge per Cycle:	7.8 - 8.6 Gal
Max. Instantaneous Discharge Rate:	90 GPM (w/2" outlet check)
Steam Consumption:	~3 lbs per 1000 lbs. of liquid pumped
Air Consumption:	~100 SCF per 1000 lbs. of liquid pumped
Recommended Filling Head:	12"

Canadian Registration # 1352.92

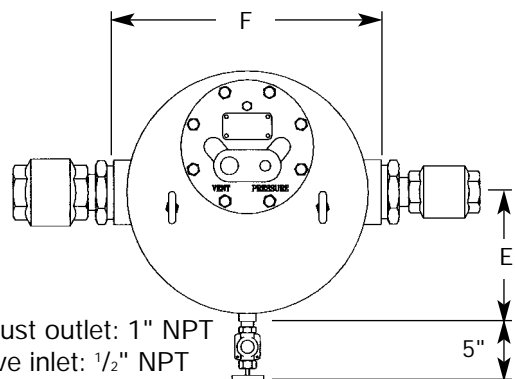
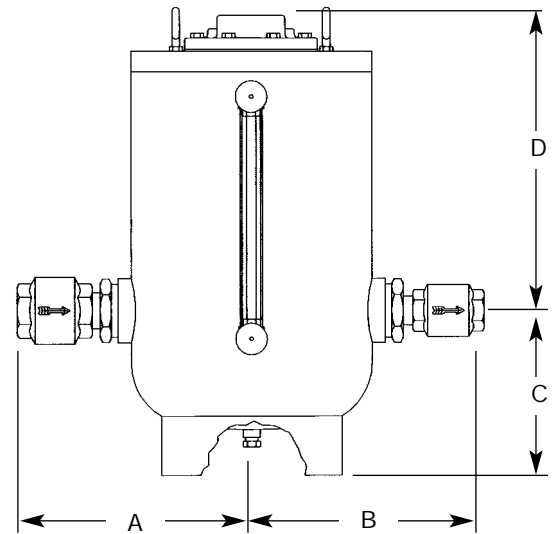

Exhaust outlet: 1" NPT
Motive inlet: 1/2" NPT

See Capacities on page 91

Connections:
1" x 1" to 3" x 2" Screwed

Size	Inches (mm)						Weight lbs(kg)
	A	B	C	D ¹	E [*]	F	
1" x 1"	13 ³ / ₈ (340)	13 ³ / ₈ (340)	11 (279)	21 ³ / ₄ (552)	9 (228)	17 ³ / ₄ (451)	168 (76)
1 1/2" x 1 1/2"	14 ³ / ₄ (375)	14 ³ / ₄ (375)	11 (279)	21 ³ / ₄ (552)	9 (228)	17 ³ / ₄ (451)	170 (77)
2" x 2"	15 (381)	15 (381)	11 (279)	21 ³ / ₄ (552)	9 (228)	17 ³ / ₄ (451)	173 (79)
3" x 2"	16 1/2 (419)	15 (381)	11 (279)	21 ³ / ₄ (552)	9 (228)	17 ³ / ₄ (451)	185 (84)

^{*}Add 5" for Water Gage.

¹Allow additional 21" clearance for maintenance.

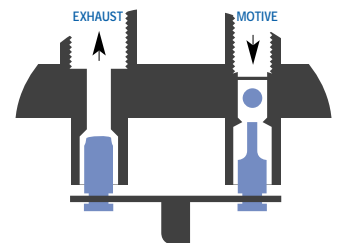

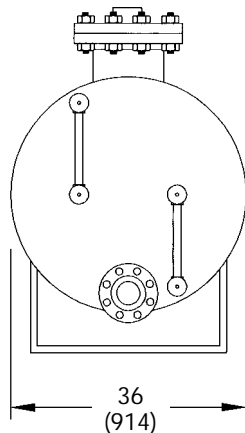
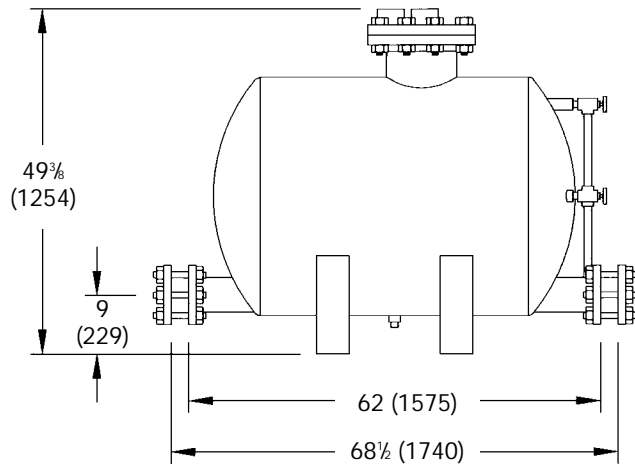

Exhaust outlet: 2" NPT
Motive inlet: 2" NPT

Dimensions—Inches (mm)

See Capacities on page 91

Connections:
4" x 4" Flanged

Canadian Registration # 1350.9

CONDENSATE COMMANDER BIG BOY PUMP

SPECIFICATION

Pump shall be a pressure vessel drainer operated by steam, compressed air or other pressurized gas to 150 psig. Body shall be fabricated steel ASME code to 150 psi. Mechanism shall employ one spring operating in continuous compression. Springs shall be warranted for the life of the unit. When required, unit shall be equipped with an external cycle counter and sight glass.

MAXIMUM OPERATING CONDITIONS

PMO:	
Max. Operating Pressure	150 psig (10.3 barg)
TMO:	
Max. Operating Temperature	400°F (204°C)
PMA:	
Max. Allowable Pressure	150 psig (10.3 barg)
TMA:	
Max. Allowable Temperature	400°F (204°C)

MATERIALS OF CONSTRUCTION

Tank Weldment	Steel
Trip Mechanism w/Flange	Stl/SS
Gasket	Non-asbestos
Stud, Flange	Steel
Nut, Hex	Steel
Nameplate	Aluminum
Drive Screw	Steel
Pipe Plug, 3/4" NPT	Steel
Water Level Gage	Bronze
Inlet Check Valve	Bronze/Stainless Steel
Inlet Flange	Steel
Outlet Check Valve	Bronze/Stainless Steel
Outlet Flange	Steel

OPERATING CHARACTERISTICS

Pump Discharge per Cycle:	140 - 185 Gal
Max. Instantaneous Discharge Rate:	195 GPM
Steam Consumption:	~3 lbs per 1000 lbs. of liquid pumped
Air Consumption:	~100 SCF per 1000 lbs. of liquid pumped
Recommended Filling Head:	24"

Canadian Registration # 1350.9

OPTIONS

- High Back Pressure for back pressures above 60 psi

CONDENSATE COMMANDER HORIZONTAL PUMP SPECIFICATION

Pump shall be a pressure vessel drainer operated by steam, compressed air or other pressurized gas to 250 psig. Body shall be fabricated steel ASME code to 250 psi. Pump mechanism shall be all stainless steel without external packing or seals. Mechanism shall employ one spring operating in continuous compression. Spring shall be warranted for the life of the unit. When required, unit shall be equipped with an external cycle counter, sight glass and insulating jacket.

MAXIMUM OPERATING CONDITIONS

PMO:		
Max. Operating Pressure	250 psig	(17.2 barg)
TMO:		
Max. Operating Temperature	400°F	(204°C)
PMA:		
Max. Allowable Pressure	250 psig	(17.2 barg)
TMA:		
Max. Allowable Temperature	400°F	(204°C)

MATERIALS OF CONSTRUCTION

Tank Weldment	Steel
Trip Mechanism w/Flange	DI/Stl/SS
Gasket	Non-asbestos
Bolt, Hex Head	Steel
Nameplate	Aluminum
Drive Screw	Steel
Pipe Plug, 1/2" NPT	Steel
Water Level Gage	Bronze
Inlet Reducer	M. Iron
Inlet Nipple	Steel
Inlet Check Valve	Bronze/Stainless Steel
Outlet Reducer	M. Iron
Outlet Nipple	Steel
Outlet Check Valve	Bronze/Stainless Steel

OPERATING CHARACTERISTICS

Pump Discharge per Cycle:	8.8 - 11 Gal
Max. Instantaneous Discharge Rate:	90 GPM (w/2" outlet check)
Steam Consumption:	~3 lbs per 1000 lbs. of liquid pumped
Air Consumption:	~100 SCF per 1000 lbs. of liquid pumped
Recommended Filling Head:	12"

Canadian Registration # 1351.9

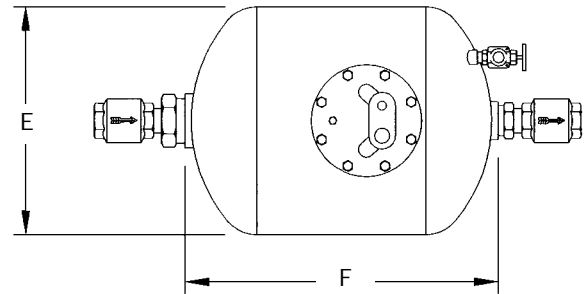
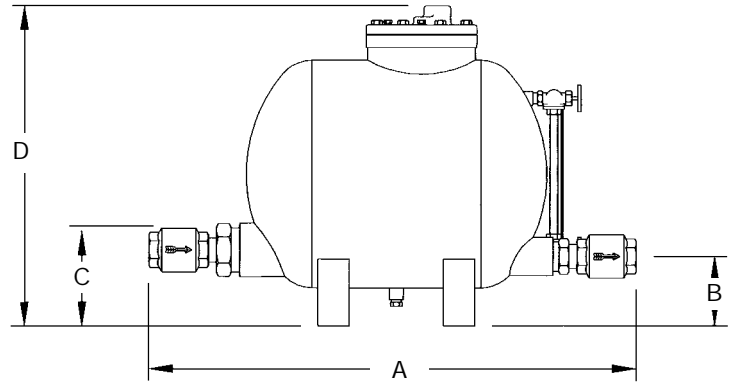

Exhaust outlet: 1" NPT
Motive inlet: 1/2" NPT

See Capacities on page 91

Connections:
1" x 1" to 3" x 2" Screwed

Dimensions							
Size	Inches (mm)						Weight lbs(kg)
	A	B	C	D ¹	E	F	
1" x 1"	34 3/4 (879)	5 1/2 (140)	6 (152)	25 1/4 (641)	18 (457)	25 (635)	174 (79)
1 1/2" x 1 1/2"	36 3/4 (933)	5 1/2 (140)	6 (152)	25 1/4 (641)	18 (457)	25 (639)	178 (81)
2" x 2"	37 3/4 (943)	5 1/2 (140)	6 (152)	25 1/4 (641)	18 (457)	25 (639)	183 (83)
3" x 2"	38 3/4 (971)	5 1/2 (140)	6 (152)	25 1/4 (641)	18 (457)	25 (639)	190 (86)

¹Allow additional 21" clearance for maintenance.

CONDENSATE COMMANDER LITTLE BOY PUMP SPECIFICATION

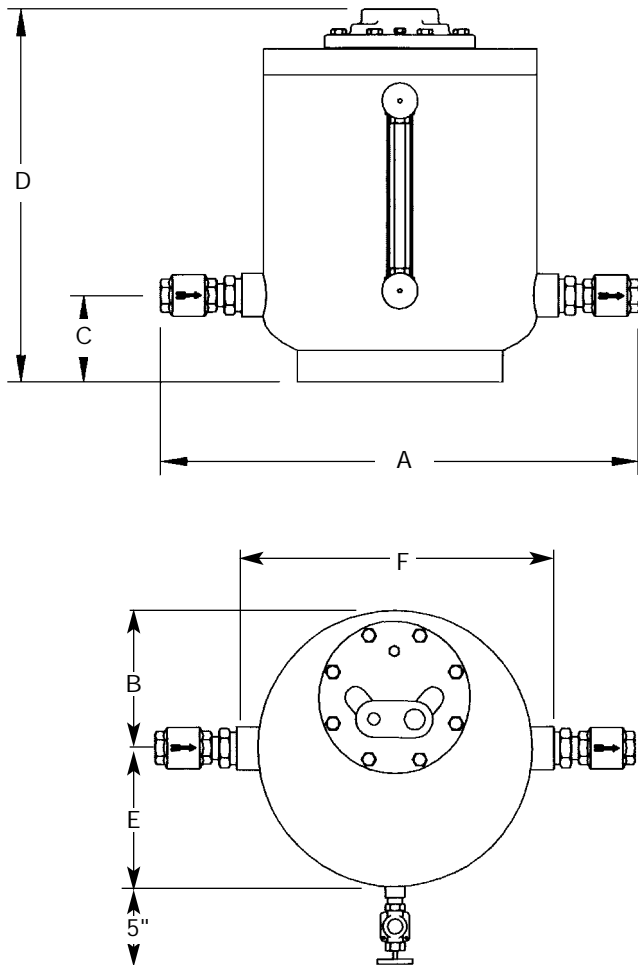

See Capacities on page 91

Connections:
1" x 1" to 1½" x 1½" NPT

Dimensions							
Size	Inches (mm)						Weight lbs(kg)
	A	B	C	D'	E*	F	
1" x 1"	26¾ (679)	8 (203)	5 (127)	21¼ (540)	9 (229)	17¾ (451)	145 (66)
1½" x 1½"	29½ (749)	8 (203)	5 (127)	21¼ (540)	9 (229)	17¾ (451)	155 (71)

*Add 5" for Water Gage.

'Allow additional 18" clearance for maintenance.

Pump shall be a pressure vessel drainer operated by steam, compressed air or other pressurized gas to 150 psig. Body shall be fabricated steel. Mechanism shall employ one spring operating in continuous compression. Spring shall be warranted for the life of the unit. When required, unit shall be equipped with an external cycle counter and sight glass.

MAXIMUM OPERATING CONDITIONS

PMO:			
Max. Operating Pressure	150 psig	(10.3 barg)	
TMO:			
Max. Operating Temperature	400°F	(204°C)	
PMA:			
Max. Allowable Pressure	150 psig	(10.3 barg)	
TMA:			
Max. Allowable Temperature	400°F	(204°C)	

MATERIALS OF CONSTRUCTION

Tank Weldment	Steel
Trip Mechanism w/Flange	DI/Stl/SS
Gasket	Non-asbestos
Bolt, Hex Head	Steel
Nameplate	Aluminum
Drive Screw	Steel
Water Level Gage	Bronze
Inlet Reducer	M. Iron
Inlet Nipple	Steel
Inlet Check Valve	Bronze/Stainless Steel
Outlet Reducer	M. Iron
Outlet Nipple	Steel
Outlet Check Valve	Bronze/Stainless Steel

OPERATING CHARACTERISTICS

Pump Discharge per Cycle:	4.2 - 5.1 Gal
Max. Instantaneous Discharge Rate:	60 GPM (w/1½" outlet check)
Steam Consumption:	~3 lbs per 1000 lbs. of liquid pumped
Air Consumption:	~100 SCF per 1000 lbs. of liquid pumped
Recommended Filling Head:	6"

Canadian Registration # 1353.92

CONDENSATE COMMANDER PUMP CAPACITY TABLE*

Motive Pressure		Back Pressure		Fill Head 6" Little Boy		Fill Head 12" Classic & Horizontal				Fill Head 24" Big Boy	Fill Head 12" Classic Duplex
psig	barg	psig	barg	1 X 1	1.5 X 1.5	1 X 1	1.5 X 1.5	2 X 2	3 X 2	4 X 4	3 X 2
250	17.24	40	2.76	-	-	2703	6392	10196	11537	-	23073
		60	4.14	-	-	3670	7203	7787	8551	-	17101
		80	5.52	-	-	3457	6071	6531	7105	-	14209
		100	6.90	-	-	3891	5278	5753	6202	-	12404
		120	8.28	-	-	3700	4730	5213	5587	-	11173
		150	10.34	-	-	3196	4074	4552	4842	-	9683
		175	12.07	-	-	2845	3624	4092	4331	-	8663
		200	13.79	-	-	2456	3152	3650	3847	-	7694
200	13.79	40	2.76	-	-	2503	5919	9441	10682	-	21364
		60	4.14	-	-	3398	6669	7210	7918	-	15835
		80	5.52	-	-	4021	5579	6110	6619	-	13238
		100	6.90	-	-	3741	4855	5403	5804	-	11607
		120	8.28	-	-	3286	4242	4768	5088	-	10177
		150	10.34	-	-	2741	3533	4058	4297	-	8593
		175	12.07	-	-	2151	2926	3476	3661	-	7321
		150	10.34	25	1.72	1814	5739	2314	5722	10376	12105
40	2.76			3058	4860	3386	7077	8465	9450	45382	18899
60	4.14			3127	4234	4464	6338	6995	7630	39757	15260
80	5.52			2620	3472	3763	4974	5607	6040	35452	12080
100	6.90			2261	2957	3168	4150	4743	5064	27971	10128
120	8.28			1935	2530	2669	3522	4156	4408	20613	8815
125	8.62	25	1.72	2470	5645	2942	6740	10712	12337	48101	24674
		40	2.76	3215	4619	3983	7197	7965	8836	44256	17672
		60	4.14	2788	3768	4066	5513	6220	6758	38625	13516
		80	5.52	2358	3117	3326	4416	5064	5432	33012	10863
		100	6.90	1920	2535	2656	3544	4216	4482	25862	8964
		115	7.93	1491	2151	1952	2976	3589	3788	17512	7575
100	6.90	15	1.03	2036	6211	2762	6393	11889	14241	47156	28482
		25	1.72	3132	5336	3763	7658	9818	11170	45212	22340
		40	2.76	3082	4323	4569	6603	7403	8164	42041	16327
		60	4.14	2534	3406	3612	4893	5641	6092	35589	12184
		80	5.52	1959	2620	2716	3681	4428	4721	27783	9442
75	5.17	15	1.03	2975	6022	3867	7978	11977	14038	46485	28075
		25	1.72	3340	4940	4649	7823	8914	10026	43084	20052
		40	2.76	2817	3891	4078	5723	6654	7273	40027	14546
		60	4.14	2003	2732	2786	3863	4721	5057	20002	10114
50	3.45	10	0.69	3701	6273	4692	9227	12492	14737	46092	29474
		25	1.72	2976	4250	4343	6387	7603	8421	39727	16843
		40	2.76	2053	2891	2863	4120	5172	5578	19899	11156
25	1.72	5	0.34	3872	6625	5825	10486	13760	16560	45329	33120
		10	0.69	3315	5063	4845	7774	9812	11193	39945	22385
		15	1.03	2751	4016	3950	6043	7657	8513	18694	17026
10	0.69	2	0.14	3894	6646	5610	10348	14520	17621	-	35242
		5	0.34	2945	4600	4150	6954	9708	11085	-	22170
5	0.34	2	0.14	2981	5115	4130	7602	11747	13781	-	27562

*Capacities shown are obtained with factory supplied check valves

For Kg/Hr multiply by .454

For other multiplex capacities, consult factory.

CONDENSATE COMMANDER PUMP SKID MOUNTED SYSTEM

Where the condensate load exceeds the capacity of one Condensate Commander Pump, multiple pumps may be used in tandem. Skid mounted units may be simplex (one pump), duplex (two pumps), triplex (three pumps) or quadruplex (four pumps). The units are equipped with a receiver, Condensate Commander Pump(s) and all necessary piping fully connected and ready for use.

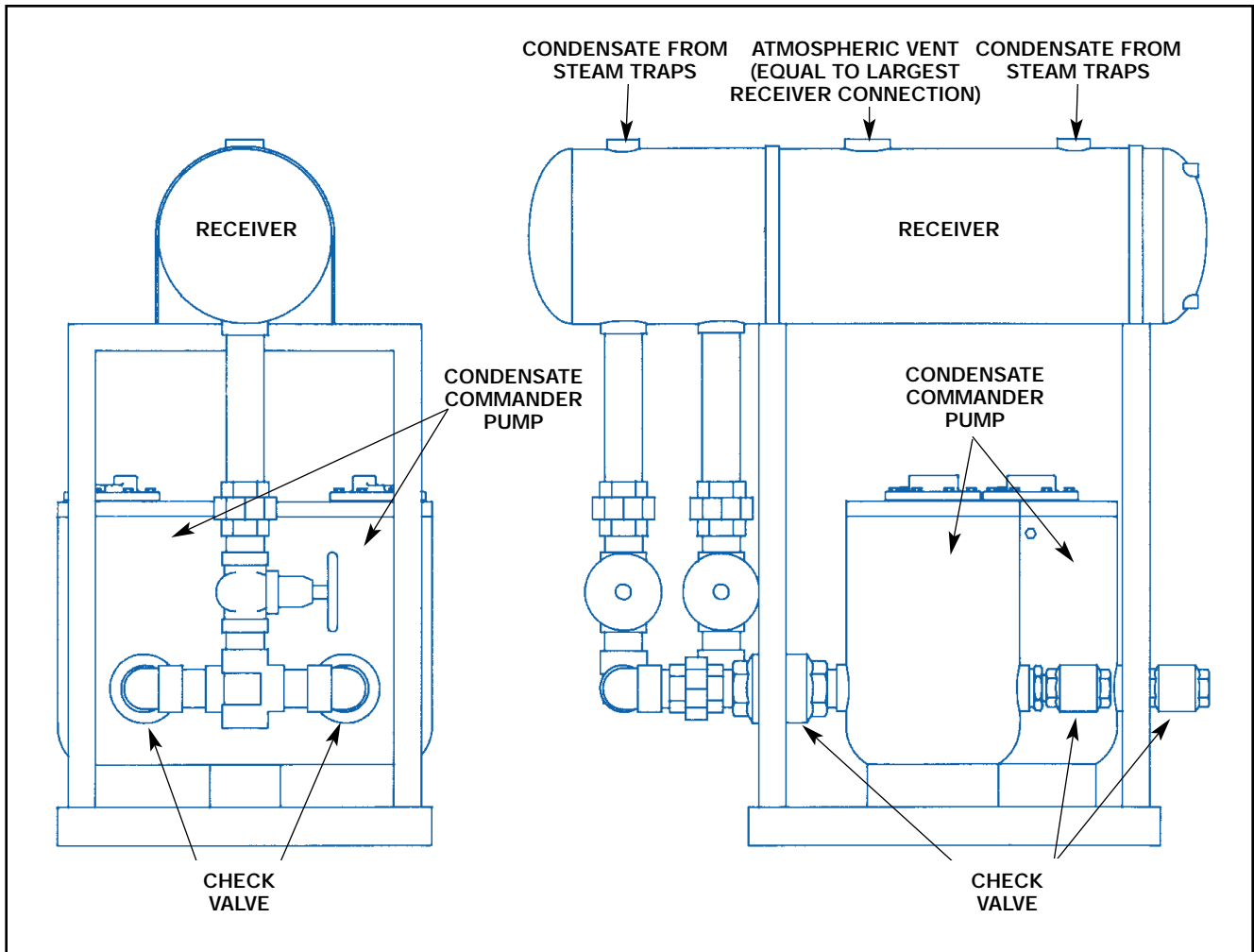

Typical Duplex Condensate Commander Pump Skid Mount System

The skid mount systems are designed to provide a complete condensate collection and condensate pump unit ready to pipe. All necessary connections are in place. The filling head dimension has already been determined.

CONDENSATE COMMANDER PUMP SKID MOUNTED SYSTEM

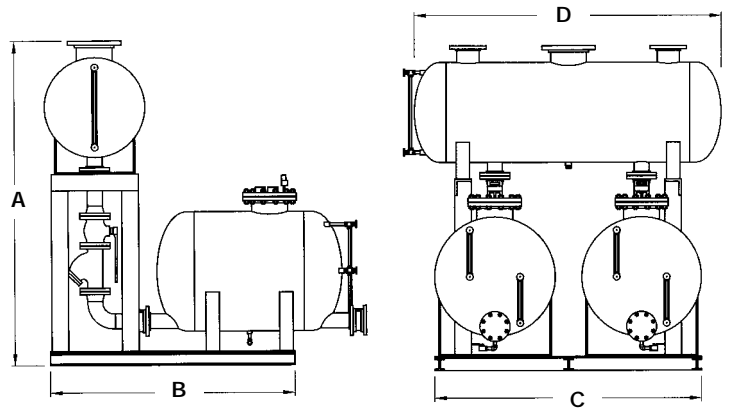

BIG BOY

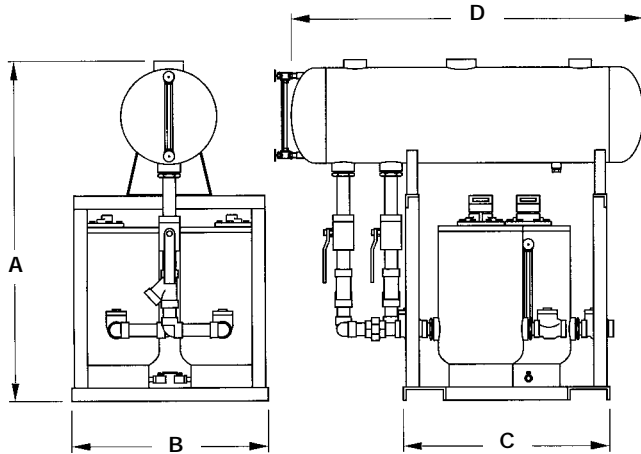

CLASSIC VERTICAL

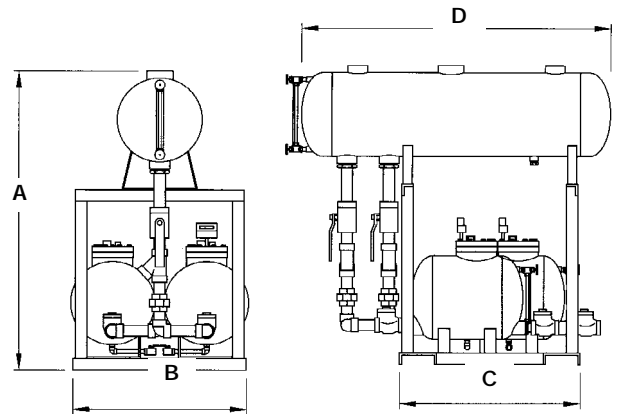

CLASSIC HORIZONTAL

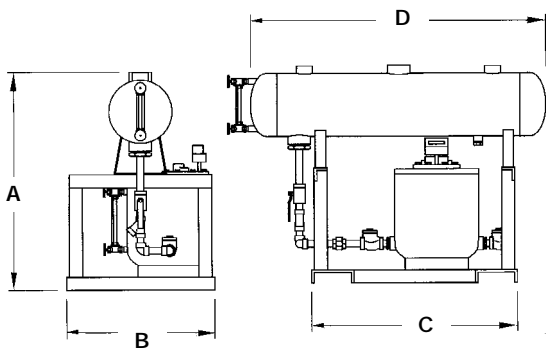

LITTLE BOY

*The layout for the Big Boy Simplex is the same as the Classic Horizontal.

Dimensions							
Style	Config-uration	Receiver Gallons	Inches (mm)				Weight lb (kg)
			A	B	C	D	
Little Boy	Simplex	25	41 ½ (1054)	27 (686)	39 (991)	56 (1422)	435 (198)
Classic, Vertical	Simplex	25	58 ½ (1486)	27 (686)	39 (991)	56 (1422)	576 (262)
		65	64 ½ (1638)	27 (686)	39 (991)	66 ½ (1689)	635 (289)
Classic, Vertical	Duplex	65	64 ½ (1638)	36 (914)	39 (991)	66 ½ (1689)	1050 (477)
		80	66 ½ (1689)	36 (914)	39 (991)	68 (1727)	1095 (498)
Classic, Horizontal	Simplex	25	58 ½ (1486)	27 (686)	39 (991)	56 (1422)	596 (2713)
		65	64 ½ (1638)	27 (686)	39 (991)	66 ½ (1689)	655 (298)
Classic, Horizontal	Duplex	65	64 ½ (1638)	36 (914)	39 (991)	66 ½ (1689)	1095 (498)
		80	66 ½ (1689)	36 (914)	39 (991)	68 (1727)	1135 (516)
Big Boy	Simplex*	115	87 ¾ (2228)	50 (1270)	70 ½ (1791)	96 (2438)	1900 (864)
Big Boy	Duplex	250	97 ¾ (2482)	76 (1930)	80 (2032)	92 (2337)	3050 (1386)

CONDENSATE COMMANDER PUMP PRIMER

The SPENCE Condensate Commander belongs to a class of pressure operated pumps primarily intended to move condensate or other fluids without the use of electricity. When compared to conventional electrical pumps, the Condensate Commander is particularly suited to pumping "difficult" media such as high temperature condensate and corrosive fluids. Pressure operated pumps and the Condensate Commander in particular enjoy a reputation of long life with very little required maintenance. Generally these types of pumps, by eliminating rotating seals, electrical motors, and impellers, last five to ten times as long as conventional electrical pumps while eliminating most of the standard maintenance.

- Returns hot condensate conserving boiler feed water chemicals and reducing fuel cost associated with reheating boiler feed water.
- Pumps without requiring electrical service.
- Pump design provides safe operation for hazardous or explosive environments.
- Operates on steam, compressed air or gas from 5 psig to 250 psig depending on model.
- Capacities to 48,000 lbs./hr.

OPERATION

The Condensate Commander pumps by displacing fluid with steam or compressed gas. The float is connected to a linkage and spring that simultaneously actuates a motive valve and an exhaust valve. During the fill cycle the motive valve closes while the exhaust valve

opens, allowing condensate to fill the pump housing. When the float, rising with the entering fluid level, reaches the top of its stroke, the mechanism releases the spring, opening the motive and closing the exhaust valves. Steam or compressed gas then flows into the pump displacing the fluid. Check valves positioned at the inlet and outlet of the pump direct the fluid in the direction of the flow.

CHARACTERISTICS

Flow capacity is dependent on several parameters. Bearing in mind that that the Condensate Commander pumps in discreet, relatively consistent slugs of fluid, the total capacity will depend on how quickly the Commander cycles. Motive pressure available and resistance in the flow line are the obvious causative and limiting factors of capacity. Less obvious is the Cv of the check valves, pressure or head of the incoming fluid, resistance in the vent line, and characteristics of the motive gas used.

There is no "vacuum" side of a Commander pump. While there certainly is an inlet side, it is important to understand that the class of pumps the Condensate Commander belongs to does not draw or suck fluid into it. The media must flow by gravity into the pump. The greater the pressure and/or head, the greater the Cv of the inlet check, and to a lesser extent the greater the Cv of the exhaust vent, the faster the fill portion of the cycle will complete. With the fill portion completed the Commander mechanism will shut off the exhaust vent and open the motive valve. Steam or compressed

gas will now displace the fluid contained in the pump housing. Factors controlling the speed of the discharge portion of the cycle include pressure of motive steam or gas, outlet check Cv, downstream backpressure, and potentially temperature of flow media and/or ambient conditions if steam is utilized as the motive gas. This last component is often overlooked, but the fact that steam will condense and reduce actual motive pressure could become significant in some applications.

RECEIVER

Conventional electric condensate pumps typically require a receiver sized to allow condensate to cool and vent flash steam. This is necessary, as the suction side of the pump will lower pressure potentially allowing the hot condensate to boil as it is drawn past the impeller. This action, known as cavitation, will quickly erode the impeller. While the temperature of the flow media is generally not a concern it must be remembered that the Condensate Commander pumps in discrete cycles. While the Commander is expelling fluid the body is pressurized and cannot receive fluid. If fluid is draining to the Commander in a continuous fashion, a receiver sized to accommodate the maximum volume expected during the time required to discharge the commander must be utilized. Failure to do so will back condensate up and possibly increase pressure, potentially causing problems.

CONDENSATE COMMANDER PUMP SELECTION GUIDELINES

To correctly select a Condensate Commander Pump that meets the requirements of the application, some specific data is needed.

1. Condensate load in lbs/hr. *
2. Motive pressure available (air or steam).
3. Total lift in feet (hydraulic head).
4. Pressure in return piping.
5. Filling head available in inches (recommended minimum of 12 inches).

EXAMPLE 1, Steam motive:

1. Condensate Load: 4,000 lb/hr.
2. Steam pressure available: 50 psig
3. Total vertical lift: 20 ft.
4. Pressure in return piping: 10 psig
5. Filling head available: 12 inches
For filling head other than 12 inches, multiply capacity by correction factor found in Table 3.

SOLUTION:

1. Calculate total back pressure. Back pressure is the total head in feet multiplied by 0.433 plus the pressure in the return piping.

$$(20 \text{ ft.} \times .433) + 10 \text{ psig} = 19$$

2. Select from the Pump Capacity Table a pump with 50 psig motive pressure and greater than 19 (25) psig total back pressure: a 1" x 1" Condensate Pump.

EXAMPLE 2, Air motive:

(conditions same as Example 1)

1. To determine correction factor for air, divide total back pressure from Example 1 by motive pressure available (BP÷MP).

$$19 \div 50 = 38\%$$

Correction factor from Table 2 is 1.10

2. Divide required condensate load by correction factor.

$$4000 \div 1.10 = 3636$$

Select from the Pump Capacity Table (Table 1) a 1" x 1" Condensate Pump.

*CONVERSIONS:

GPM to lbs/hr.: GPM x 500

Lbs/hr to GPM: Lbs/hr. x .002

Lbs/hr to KG/hr: Lbs/hr. x .454

Operating Pressure Inlet (psig)	Total Backpressure (psig)	Stainless Steel Check Valves				
		1"x1"	1½"x1½"	2"x2"	3"x2"	3"x2" Duplex
5	2	4130	7602	11747	13781	27562
10	5	4150	6954	9708	11085	22170
	2	5610	10348	14520	17621	35242
25	15	3950	6043	7657	8513	17026
	10	4845	7774	9812	11193	22386
	5	5825	10486	13760	16560	33120
50	40	2863	4120	5172	5578	11156
	25	4343	6387	7603	8421	16842
	10	4692	9227	12492	14737	29474
75	60	2786	3863	4721	5057	10114
	40	4078	5723	6654	7273	14546
	15	3867	7978	11997	14038	28076
100	80	2716	3681	4428	4721	9442
	60	3612	4893	5641	6092	12184
	40	4569	6603	7403	8164	16328
	15	2762	6393	11889	14241	28482
125	115	1952	2976	3589	3788	7576
	100	2656	3544	4216	4482	8964
	80	3326	4416	5064	5432	10864
	60	4066	5513	6220	6758	13516
	40	3983	7197	7965	8836	17672
	25	2942	6740	10712	12337	24674
150	120	2669	3522	4156	4408	8816
	100	3168	4150	4743	5064	10128
	80	3763	4974	5607	6040	12080
	60	4464	6338	6995	7630	15260
	40	3386	7077	8465	9450	18900
	25	2314	5722	10376	12105	24210

TABLE 2 – Capacity Correction Factors for Motive Gas Supply other than Steam

% Back Pressure vs. Motive Pressure (BP ÷ MP)								
10%	20%	30%	40%	50%	60%	70%	80%	90%
1.04	1.06	1.08	1.10	1.12	1.15	1.18	1.23	1.28

TABLE 3 – Capacity Correction Factor for Filling Head Variation

Filling Head (inches)	Check Valve and Piping Size Inches				
	1"	1½"	2"	3" x 2"	4"
6	0.70	0.70	0.70	0.84	—
12	1.00	1.00	1.00	1.0	0.7
24	1.20	1.20	1.20	1.08	1.0
36	1.35	1.35	1.35	1.20	1.1
48	—	—	—	—	1.15

TYPICAL INSTALLATION OF A CONDENSATE COMMANDER PUMP WITH A VENTED RECEIVER

Condensate is being pumped from a vented receiver to an overhead elevated condensate return line that may contain pressure. For safety, the pump exhaust and receiver should be vented to atmosphere if steam is used for the motive pressure.

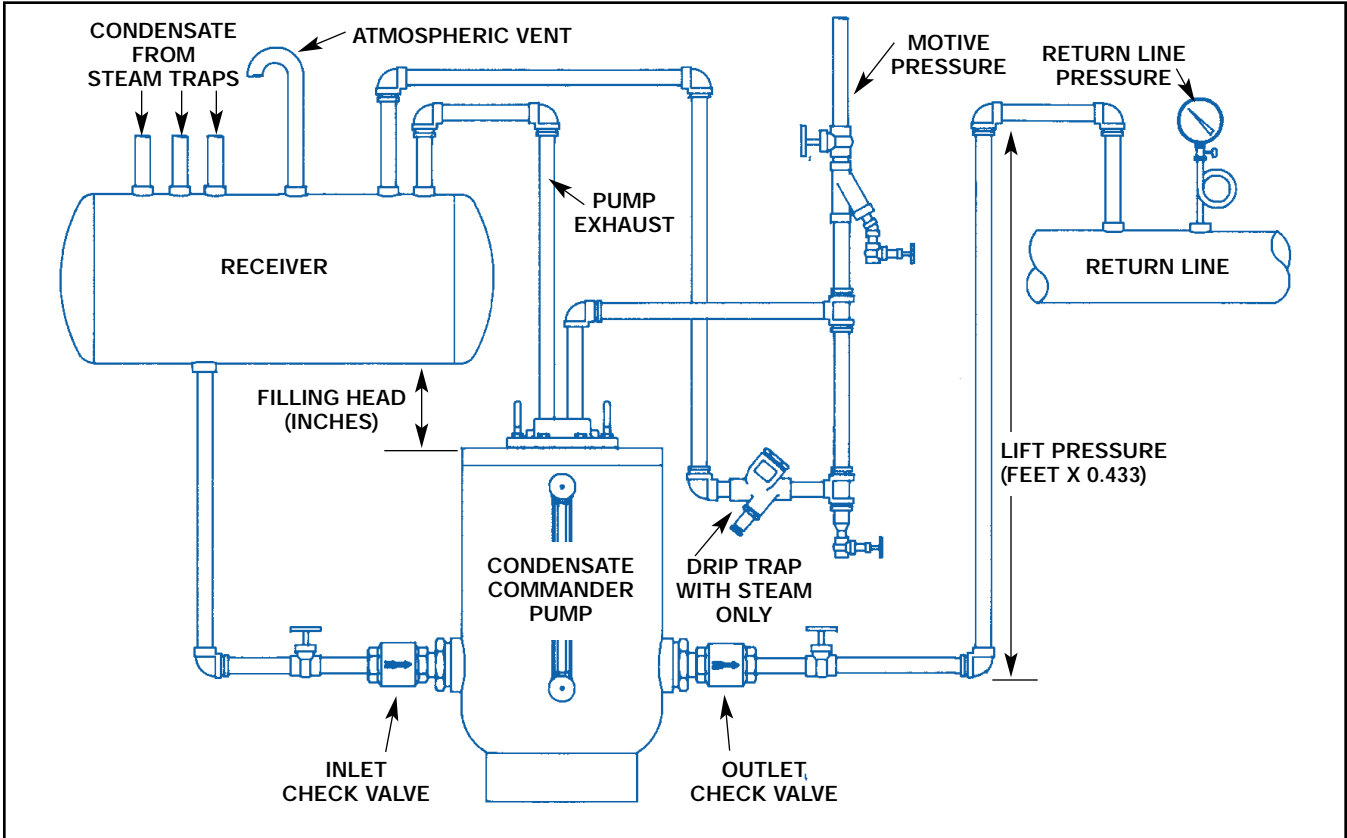

To efficiently drain condensate from an open system, the vented receiver should be horizontally located a minimum of twelve inches above the pump. To allow for sufficient volume of condensate and flash vapor, the receiver must be sized adequately to permit the complete separation of flash vapor from condensate. The receiver may be either an ASME coded tank or a length of large diameter pipe.

Sizing Example: Condensate Load = 10,000 lb/hr. Traps are draining a Heat Exchanger running at 100 psig and the receiver is vented to atmosphere. Table 5 shows 13.3% of the condensate flashes to steam, so total flash steam = 10,000 x .133 = 1,333 lb/hr flash steam. Table 4 indicates a vent size of 6" and a receiver size of 16" Dia. x 36" long.

TABLE 4 - Vented Receiver Sizing
Receiver size based on 36" OAL

Flash Vapor (lbs/hr)	Pipe Diameter (inches)	Vent Line Size (inches)
75	4	1½
150	6	2
300	8	3
600	10	4
900	12	6
1200	16	6
2000	20	8

TABLE 5 - Percent of Flash Steam Formed

Initial Steam Pressure psig	Sat. Temp. °F	Receiver Tank Pressure, psig							
		0	5	10	20	30	40	50	75
10	239	3.0	2.0	0	0	0	0	0	0
25	267	5.7	4.1	3.0	1.0	0	0	0	0
50	298	9.0	7.4	6.2	4.3	2.6	1.0	0	0
75	320	11.3	10.8	8.6	6.7	5.0	3.7	2.5	0
100	338	13.3	11.7	10.6	8.7	7.0	5.7	4.6	2.2
125	353	14.8	13.4	12.2	10.3	8.7	7.4	6.3	3.8

TYPICAL INSTALLATION OF A CONDENSATE COMMANDER PUMP IN A CLOSED SYSTEM

Condensate is flowing from a pressurized system to another pressurized system with greater pressure. Both the inlet and return line may be elevated. This installation will also service a high capacity process installation using a pressurized receiver.

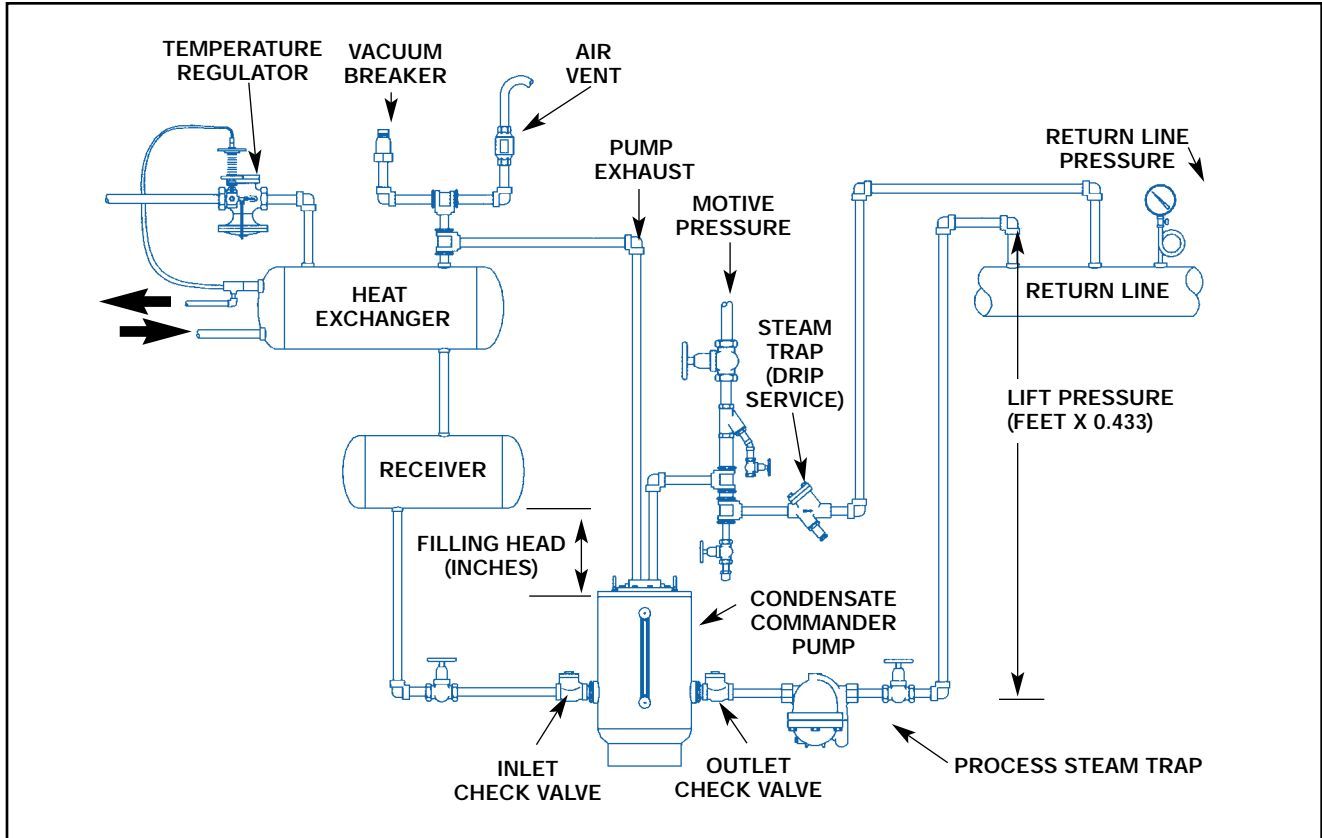

To efficiently drain condensate in a closed system, the receiver should be horizontally located a minimum of twelve inches above the pump to allow for sufficient condensate collection. The receiver must be sized to provide the minimum condensate capacity required to prevent equipment flooding. The receiver may be either an ASME coded tank or a length of large diameter pipe. A safety relief valve may be required. Consult factory for capacity when a steam trap is utilized after the pump.

TABLE 6 - Inlet Receiver Sizing

Liquid (lb/hr)	Receiver Pipe Size (feet)				
	3"	4"	6"	8"	10"
>500	2	—	—	—	—
1000	2	—	—	—	—
1500	3	2	—	—	—
2000	3.5	2	1	—	—
3000	—	3	2	—	—
4000	—	4	2	1	—
5000	—	6	3	2	—
6000	—	—	3	2	—
7000	—	—	3	2	—
8000	—	—	4	2	—
9000	—	—	4.5	3	2
10,000	—	—	5	3	2
11,000	—	—	5	3	2

TYPICAL INSTALLATION OF A CONDENSATE COMMANDER PUMP IN A SUBMERGED APPLICATION

Liquid is pumped from a sump, manhole or other low-lying area where it may accumulate. For back pressure applications, multiply the total vertical lift by .5 plus any back pressure in the return line.

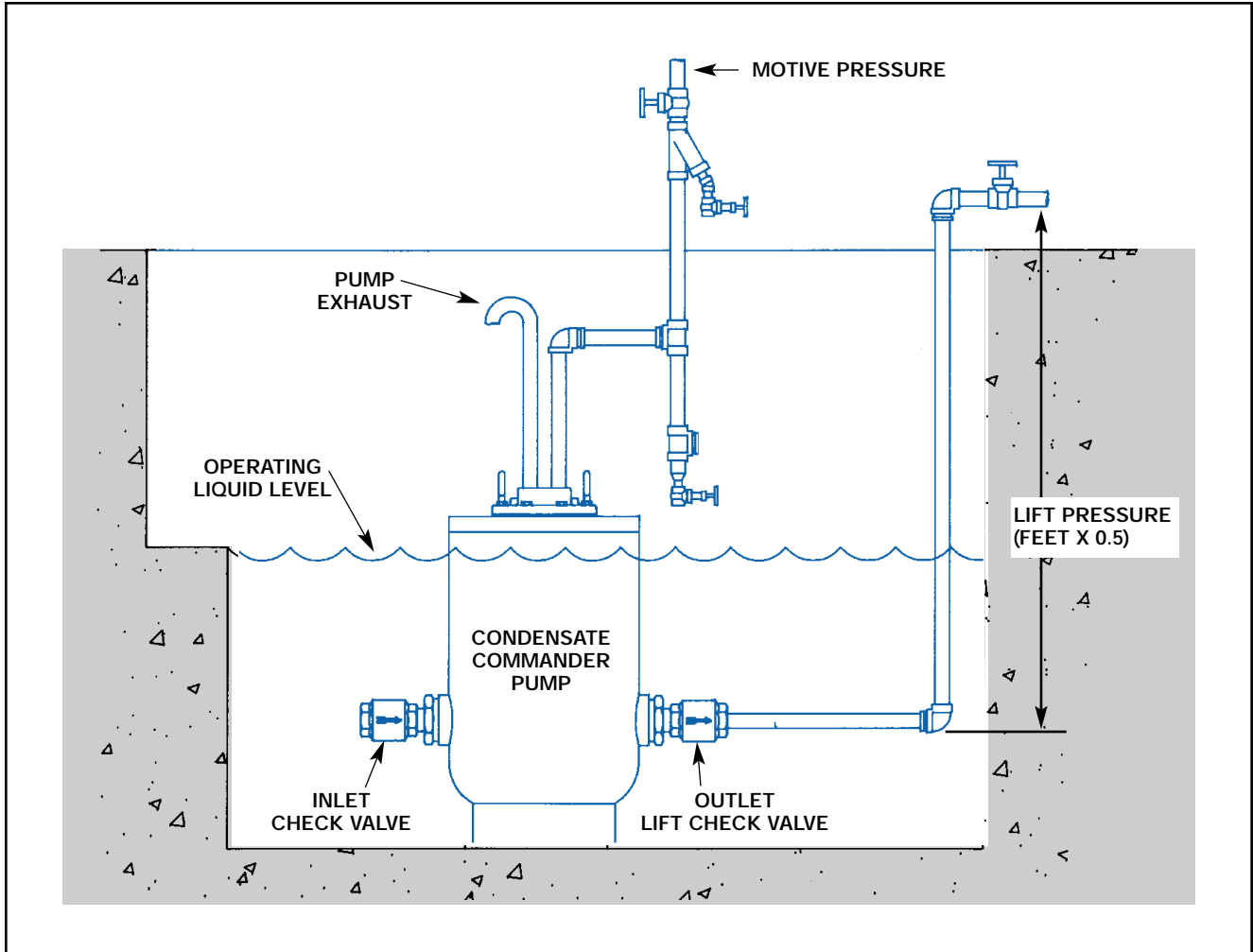

Condensate Commander Pumps can pump liquids from low lying areas such as manholes, steam pits or any area that may collect liquid or flood. The non-electric feature makes it a good choice if compressed air or any other gas is readily available for use as the driving force. Steam is not recommended as a motive vapor because a submerged pump may quickly condense the motive steam, potentially reducing performance.