

ABB MEASUREMENT & ANALYTICS | DATA SHEET

PGS100 and PAS100

Gauge and absolute pressure transmitters



Measurement made easy

Engineered solutions for all applications

Standard overload resistance

Base accuracy

- $\pm 0.25\%$ ($\pm 0.1\%$ on request)

Span limits

- 4 – 10000 kPa; 16 inH₂O up to 1450 psi
- 4 – 10000 kPa abs; 30 mmHg up to 1450 psia

Proven sensor technology together with state-of-the-art digital technology

- Valuable turn down ratio of up to 10:1

Stainless steel housing

- Optimized for use in industrial process environments
- Extremely robust

New touch keypad technology

- allows quick and easy local configuration without opening the cover, even in hazardous classified locations
- backlight facility

Flexible configuration options

- Local configuration via setup button for upper and lower range values
- Local configuration via buttons on HMI
- Via handheld terminal or PC user interface

PED compliance

- Category III for PS > 20 MPa, 200 bar
- Sound Engineering Practice (SEP) for PS \leq 20 MPa, 200 bar

Product in compliance with Directive 2011/65/UE (RoHS II)

In-built advanced diagnostics

Functional – specification

Range and span limits

Sensor code	Upper range limit (URL)	Lower range limit (LRL)	Minimum measuring span	
			Model PGS Gauge pressure	Model PAS Absolute pressure
F	40 kPa	-40 kPa	4 kPa	4 kPa
	400 mbar	-400 mbar	40 mbar	40 mbar
	160 inH ₂ O	-160 inH ₂ O	16 inH ₂ O	30 mmHg
L	250 kPa	-100 kPa	25 kPa	25 kPa
	2500 mbar	-1 bar	250 mbar	250 mbar
	1000 inH ₂ O	-14.5 psi	100 inH ₂ O	172.5 mm Hg
D	1000 kPa	-100 kPa	100 kPa	100 kPa
	10 bar	-1 bar	1 bar	1 bar
	145 psi	-14.5 psi	14.5 psi	750 mmHg
K	4000 kPa	-100 kPa	400 kPa	400 kPa
	40 bar	-1 bar	4 bar	4 bar
	580 psi	-14.5 psi	5.8 psi	5.8 psi
R	10000 kPa	-100 kPa	1000 kPa	1000 kPa
	100 bar	-1 bar	10 bar	10 bar
	1450 psi	-14.5 psi	145 psi	145 psi

IMPORTANT (NOTE)

The lower range limit (LRL) for model PAS is 0 absolute for all measuring ranges.

Span limits

Maximum span = upper range limit (URL)

To optimize performance characteristics, it is recommended that you select the transmitter sensor code providing the lowest turn down ratio.

TURNDOWN = Upper range limit / set span

Zero suppression and elevation

Zero and span can be adjusted to any value within the range limits detailed in the table as long as:

– calibrated span \geq minimum span

Damping

Configurable time constant between 0 and 60 s.

This is in addition to the sensor response time, and can be adjusted via the optional display, handheld terminal, or PC user interface.

Warm-up time

Ready for operation as per specifications in less than 10 s with minimum damping.

Insulation resistance

>100 M Ω at 500 V DC (between terminals and ground, according to EN61010-1 and EN62828-1 par 6.2.3.2).

Specification – operative limits

Pressure limits

Overpressure limits

Without damage to the transmitter

No damage will occur during transmitter operation, if they are used within the specifications and subject to the following limits:

Sensor code	Overpressure limits, 0 abs to:
F	1 MPa, 10 bar, 145 psi
L	3 MPa, 30 bar, 435 psi
D	6 MPa, 60 bar, 870 psi
K	8 MPa, 80 bar, 1160 psi
R	20 MPa, 200 bar, 2900 psi

Test pressure

When carrying out the transmitter pressure test, it is essential to observe the overpressure limits.

Temperature limits °C (°F)

Ambient

This is the operating temperature.

Model PGS, PAS	Ambient temperature limits
Operating temperature range	-40 and 85 °C (-40 and 185 °F)
LCD display readability	-20 and 70 °C (-4 and 158 °F)

IMPORTANT (NOTE)

For Hazardous Atmosphere applications see the temperature range specified on the certificate/approval relevant to the aimed type of protection.

Process

Model PGS, PAS	Process temperature limits
Process temperature range	-50 and 120 °C (-58 and 248 °F)

Storage

Model PGS, PAS	Storage temperature limits
Storage temperature range	-50 and 85 °C (-58 and 185 °F)
LCD display	-40 and 85 °C (-40 and 185 °F)

Model PGS, PAS	Humidity during storage
Relative humidity	Up to 75 %

Environmental limits

Electromagnetic compatibility (EMC)

The devices comply with the requirements and tests for EMC Directive 2014/30/EU to standards EN 61326-1 Table2 (industrial electromagnetic environment) concerning both emitted interference (CISPR11) and interference immunity.

- Burst test: up to 2 kV at 5 kHz and 100 kHz
- Surge test: up to 1 kV line-line and 2 kV line-ground

Radiated emission: Group 1 - class B according to CISPR11

- FCC 47 CFR part 18.305
- ICES 005 - Issue 4

Conducted emission: group 1 - class A according to CISPR11 and to CISPR32

- ICES 005 -Issue 4

Pressure equipment directive (PED)

Comply with 2014/68/EU to standards ANSI/ISA S82.03

- Category III Module H for PS > than 20 MPa, 200 bar
- Sound Engineering Practice (SEP) for PS ≤ 20 MPa, 200 bar.

Humidity

Relative humidity: up to 100 %

Condensation, icing: permissible

Vibration resistance

Acceleration at frequencies of

- 10 – 60 Hz with displacement of 0.7 mm
 - 60 – 1000 Hz 5 g (50 m/s²)
- (according to IEC 60068-2-6).

Shock resistance

Test Ea Half sine with 3 positive and 3 negative shocks for each axis

- Acceleration: 50 g
- Duration: 11 ms

Continuous test Ea half sine with 1000 positive and 1000 negative shocks for each axis

- Acceleration: 10 g
- Duration: 10 ms

(according to IEC 60068-2-27)

Wet and dust-laden atmospheres (IP degree of protection)

The transmitter is dust and sand-tight, and is protected against immersion effects as defined by the following standards:

- IEC EN60529 to IP66, IP67, IP68
- ISO 20653 to IP69K
- NEMA 4X

IP65 degree of protection with plug connection.

Tested ambient

The transmitter is suitable for class D1, non weather-protected locations, outdoor locations (according to IEC 60654-1)

Hazardous atmospheres

Without integral display

INTRINSIC SAFETY Ex ia:**ATEX Europe approval (code HAM)**

- II 1 G Ex ia IIC T4 Ga
- II 1/2 D Ex ia IIIC T135°C Da/Db
- II 1/2 D Ex ta/tb IIIC T135°C Da/Db;

IECEX approval (code HJM)

- Ex ia IIC T4 Ga
- Ex ia IIIC T135°C Da/Db
- Ex ta/tb IIIC T 135°C Da/Db;

CSA approvals (code HCM)

- For US
 - Class I, Zone 0, AEx ia IIC T4 Ga
 - Class I Div 1 Gr. A, B, C, D T4 - IS
 - Class II, Div 1 Gr. E, F, G 120 °C - IS
 - Zone 20/21 AEx ia IIIC T135°C Da/Db
 - Zone 20/21 AEx ta/tb IIIC T135°C Da/Db
 - Class III, Div 1
- For Canada
 - Ex ia IIC T4 Ga
 - Class I Div 1 Gr. A, B, C, D T4 - IS
 - Class II, Div 1 Gr. E, F, G 120 °C - IS
 - Ex ia IIIC T135°C Da/Db
 - Ex ta/tb IIIC T135°C Da/Db
 - Class III, Div 1

Combined ATEX Europe, IECEX and CSA (US and Canada) approvals (code HMM)**NEPSI China approval (code HMN)**

- Without integral display
 - INTRINSIC SAFETY Ex ia:
 - Ex ia IIC T4 Ga
 - Ex iaD 20/21 T135°C
 - Ex tD A20/A21 IP6X T135°C

With integral display

INTRINSIC SAFETY Ex ia:**ATEX Europe approval (code HAM)**

- II 1 G Ex ia IIC T4 Ga

IECEX approval (code HJM)

- Ex ia IIC T4 Ga

CSA approvals (code HCM)

- For US
 - Class I, Zone 0, AEx ia IIC T4 Ga
 - Class I Div 1 Gr. A, B, C, D T4
- For Canada
 - Ex ia IIC T4 Ga
 - Class I Div 1 Gr. A, B, C, D T4

NEPSI China approval (code HMN)

With integral display

- INTRINSIC SAFETY Ex ia:
 - Ex ia IIC T4 Ga

IMPORTANT (NOTE)

For dust applications with process temperatures from 85°C to 120°C the installer shall ensure that the temperature at a particular location on the equipment does not exceed a specified value for any particular equipment installation. (i.e. 85 °C maximum for gaskets of filter and cover)

REFER TO CERTIFICATES FOR AMBIENT TEMPERATURE RANGES RELATED TO THE DIFFERENT TEMPERATURE CLASSES.

Specification - Electrical data and options

HART digital communication and 4 to 20 mA output

Power supply

The transmitter operates from 10.5 to 42 V DC with no load and is protected against reversed polarity (additional loads enable operation above 42 V DC).

Minimum operating voltage increases to 14.5 V DC with optional backlit LCD display.

For Ex ia and other intrinsically safe approval power supply must not exceed 30 V DC.

Ripple

Maximum permissible supply voltage ripple during communication complies with HART FSK "Physical Layer" specification rev. 8.1.

Load limitations

Total loop resistance at 4 to 20 mA and HART:

$$R \text{ (k}\Omega\text{)} = \frac{\text{Voltage supply} - \text{Minimum operating voltage (VDC)}}{22 \text{ mA}}$$

A minimum resistance of 250 Ω is required for HART communication.

Glass touch LCD display (optional)

Digital, graphic LCD display with 2-button keypad for customized visualization and configuration.

For 4 to 20 mA analog version

- visualization of output current in mA
- configuration of Zero (4mA) and Span (20mA) using the 2 buttons

For HART/4 to 20 mA version

- visualization of
 - gauge pressure/absolute pressure or
 - output current in mA or %, or
 - HART output (freely assigned start/end values and unit)
 - diagnostic messages, alarms, errors and measuring range limits violations
 - QR code diagnostics (optional)
- configuration of
 - Zero (4mA) and Span (20mA) using the 2 buttons
 - Easy setup configuration menu

Output signal

4 to 20 mA analog version

- Two-wire, 4 to 20 mA analog output signal

HART/4 to 20 mA version

- Two-wire, 4 to 20 mA analog output signal and digital process variables (% , mA or engineering units) superimposed on the 4 to 20 mA signal with protocol based to Bell 202 FSK standard H.

Output current limits for 4 to 20 mA analog version

Overload condition

- Lower limit: 3.8 mA
- Upper limit: 20.5 mA

Default alarm current

- 21 mA

Output current limits for HART/4 to 20 mA version (according to NAMUR NE 43 standard)

Overload condition

- Lower limit: 3.8 mA (settable from 3.8 to 4 mA)
- Upper limit: 20.5 mA (settable from 20 to 21 mA)

Alarm current

- Lower alarm value: 3.6 mA (settable from 3.6 to 4 mA)
- High alarm value: 21 mA (settable from 20 to 22.8 mA)

Default setting: high alarm current

NAMUR NE 43 defines as alarm limits the lower ≤ 3.6 mA and the upper ≥ 21 mA.

Risk connected to any deviation from NAMUR NE43 thresholds of the alarm current limits falls under Customers' responsibility.

HART release

Revision 7.

Specification - Performance

Reference conditions according to IEC 62828-1

- Ambient temperature constant in the range 15 – 25 °C (59 – 77 °F)
- Relative humidity constant in the range 50 – 70 %
- Ambient pressure constant in the range 860 – 1060 mbar
- Measuring span based on zero position
- Transmitter with AISI 316 L or Hastelloy C276 process isolating diaphragm
- Filling fluid: Silicone oil
- Supply voltage: 24 V DC ± 1 %
- Load with HART: 250 Ω
- Transmitter not grounded
- Characteristic setting: linear, 4 – 20 mA.

Unless otherwise specified, errors are quoted as % of calibrated span.

Some performance referring to the Upper Range Limit are affected by the actual turndown (TD) as ratio between Upper Range Limit (URL) and calibrated span.

FOR OPTIMUM MEASURING ACCURACY, IT IS RECOMMENDED THAT YOU SELECT THE SENSOR CODE WHICH WILL PROVIDE THE LOWEST TD VALUE.

Dynamic response (according to IEC 61298-2 / IEC 62828-1)

Dead time	90 ms
Time constant (63.2 % of total step response)	100 ms

Accuracy rating (E_{lin})

% of calibrated span, including combined effects of terminal based linearity, hysteresis and repeatability.

For all sensors	Turndown	Accuracy
Standard accuracy (± 0.25 %)	from 1:1 to 10:1	± 0.25 %
	from 10:1 to 20:1	$\pm 0.25\% + 0.01\% \times TD - 0.1\%$
Extended accuracy (± 0.10 %)	from 1:1 to 10:1	± 0.10 %
	from 10:1 to 20:1	$\pm 0.01\% \times TD$

Ambient temperature (E_{ATZ}+E_{ATS})

per 10K change between the limits of –10 °C to +60 °C
(per 18 °F change between the limits of 14 °C to +140 °F):

Sensor	for TD up to	
F	10:1	$\pm (0.15$ % URL + 0.15 % span)
L, D, K, R	10:1	$\pm (0.05$ % URL + 0.05 % span)

for an ambient temperature change from –10 °C to +60 °C
(+14 to +140 °F):

Sensor	for TD up to	
All	10:1	$\pm (0.20$ % URL + 0.20 % span)

per 10K change between the limits of –40 °C to –10 °C or
+60° to +85 °C (per 18 °F change between the limits of –40
to +14 °F or +140° to +185 °F):

Sensor	for TD up to	
All	10:1	$\pm (0.10$ % URL + 0.10 % span)

Power supply

Within the specified limits for the voltage / load, the total influence is less than 0.005 % of the upper measuring range limit per volt.

Load

Within the specified load / voltage limits, the total influence is negligible.

Mounting position

Nominal position: vertical; process connection at bottom.
Mounting positions deviant from the standard position influence the output due to the filling liquid.
This effect can be compensated by carrying out zero signal adjustment.

Long-term stability

± 0.25 % of URL per year as standard

Total performance

For a temperature change from –10 to 60 °C (14 to 140 °F) with TD 1:1:

- 0.42 % of calibrated span for extended accuracy
- 0.48 % of calibrated span for base accuracy

Total performance includes the measuring errors of

- non-linearity including hysteresis and repeatability
- thermal change of the ambient temperature as regards the zero signal and the calibrated span.

$$E_{\text{perf}} = \sqrt{(E_{\text{ATZ}} + E_{\text{ATS}})^2 + E_{\text{lin}}^2}$$

E_{perf} = Base accuracy

E_{ATZ} = Effect of the ambient temperature on zero

E_{ATS} = Effect of the ambient temperature on span

E_{lin} = Accuracy rating

Specification - physical

Please refer to the ordering information to check the availability of different versions of the relevant model

Materials

Process isolating diaphragms (*)

AISI 316 L ss, Hastelloy C276,
Diaflex (antiabrasion), H-Shield (for hydrogen permeation)

Process connection (*)

AISI 316 L ss

Sensor filling fluid

Silicone oil, inert fill (fluorocarbon)

Mounting bracket

AISI 304 ss

Sensor housing, electronics housing and cover

AISI 316 L ss

Filter for atmospheric ventilation

- Filter material: polyamide (PA)
- Filter housing: plastic (general purpose version), stainless steel (Ex certified versions)

Viewing window of display cover

Glass

Cover O-ring

EPDM for sensor O-ring and cover O-ring to glass;
Silicon for cover O-ring to housing

Process connection O-ring

EPDM for for front bonded connection

Plates

Nameplate, certification (if applicable) and tag (if requested) labels self-adhesive attached to the electronics housing.

Calibration

- Standard: 0 to upper range limit (URL)
- Optional: to specified measuring span

Optional extras

Mounting bracket (code BU)

Universal for vertical and horizontal 60 mm (2 in) pipes or wall mounting

Display (code Dx)

Can be rotated in 5° increments into 72 positions (suggested ± 180° clockwise/anticlockwise rotation)

Additional plate

Self-adhesive label for tag and/or calibration details (up to 20 characters). Only by ordering option **code SC** for tag purposes, tag value will both be transferred in the memory of the instrument itself and appear on the optional certificates. Please be aware that display will only show last 8 digits of tag number.

AISI 316 ss wired-on plate with laser printed customized data (4 lines of 32 characters 4 mm/0.16 in high). By ordering option **code LEW**, custom text has to be provided. In case of no text provided, wired-on plate will be delivered blank.

Be aware that if tag is only indicated as part of the custom text, it will neither be transferred in the memory of the instrument itself nor appear on the relevant certificate. If that is required, please order option code SC.

Cleaning procedure for oxygen service (code P1)

Certificates (test, design, characteristics, material traceability) (code Cx)

Approvals (code Gx)

Operating instruction language (code Mx)

Process connections

1/2 in - 14 NPT male/ 1/4 in - 18 NPT female or
1/2 in - 14 NPT female or DIN EN 837-1 G 1/2 B threads,
or G 1/2 in front bonded diaphragm.

Electrical connections

M16 x 1.5 threaded entry on housing.
M20 x 1.5 or 1/2 in - 14 NPT threaded adapters available on request (supplied loose).

Terminals

Two screw connections for signal / auxiliary power supply, for wire cross-sections from 0.5 – 1.5 mm² (16 AWG)

Grounding

Both internal and external ground terminals for wire cross-sections up to 4 mm² (12 AWG).

Weight (without options)

- Approx. 950 g (2.1 lb)
- Additional 650 g (1.5 lb) for packaging

Packaging

Carton with dimensions of approx. 180 x 160 x 130 mm (7.1 x 6.3 x 5.1 in)

(*) Wetted parts of the transmitter.

Configuration

Transmitter with HART communication and 4 – 20 mA

Standard configuration

Transmitters can be ordered optionally factory calibrated to customers specific range. The required calibrated range and tag will be printed on an additional tag plate. If a calibration range and tag is not required, the transmitter will be supplied as follows:

Engineering Unit	kPa
4 mA	Zero
20 mA	Upper Range Limit (URL)
Output	Linear
Damping	1 s
Transmitter failure mode	Upscale
Tag	Blank (up to 20 alphanumeric characters - long; only last 8 visible on display - short)
Optional display	2 line display view:- 4..20 mA + HART version: - PV in kPa - % as bargraph 4..20 mA version: - output in mA - % as bargraph
Write protection	Disabled

Any or all the above configurable parameters, including lower and upper range values which must be the same unit of measure, can be easily changed using a HART hand-held communicator or by a PC running the configuration software with DD or FDI for PGx100/PAx100.

Tag and Calibration

Tag and/or specific calibrated span shall be ordered using option code SC.

In case a calibration report is needed on a full range device, option code SC has to be ordered and full span has to be provided as calibrated span.

In case option SC is ordered for tag purposes, two tag types are available: Short Tag and Long Tag.

See below table for details about tag type applicability / presence:

Type	Max Length	On Display	On Certification	On Device Label
Short Tag	8 digits	YES	YES	NO
Long Tag	32 digits	NO	YES	YES

In order to enable Tag (either Long / Short or both) option SC is mandatory in the code

In case no specific indication will be given about the tag type, data will be considered as Long Tag by default.

In case tag is required on the optional wired-on customer data plate (optional digit LEW) specific indication needs to be given.

Mounting dimensions

(not design data) - dimensions in mm (inch)

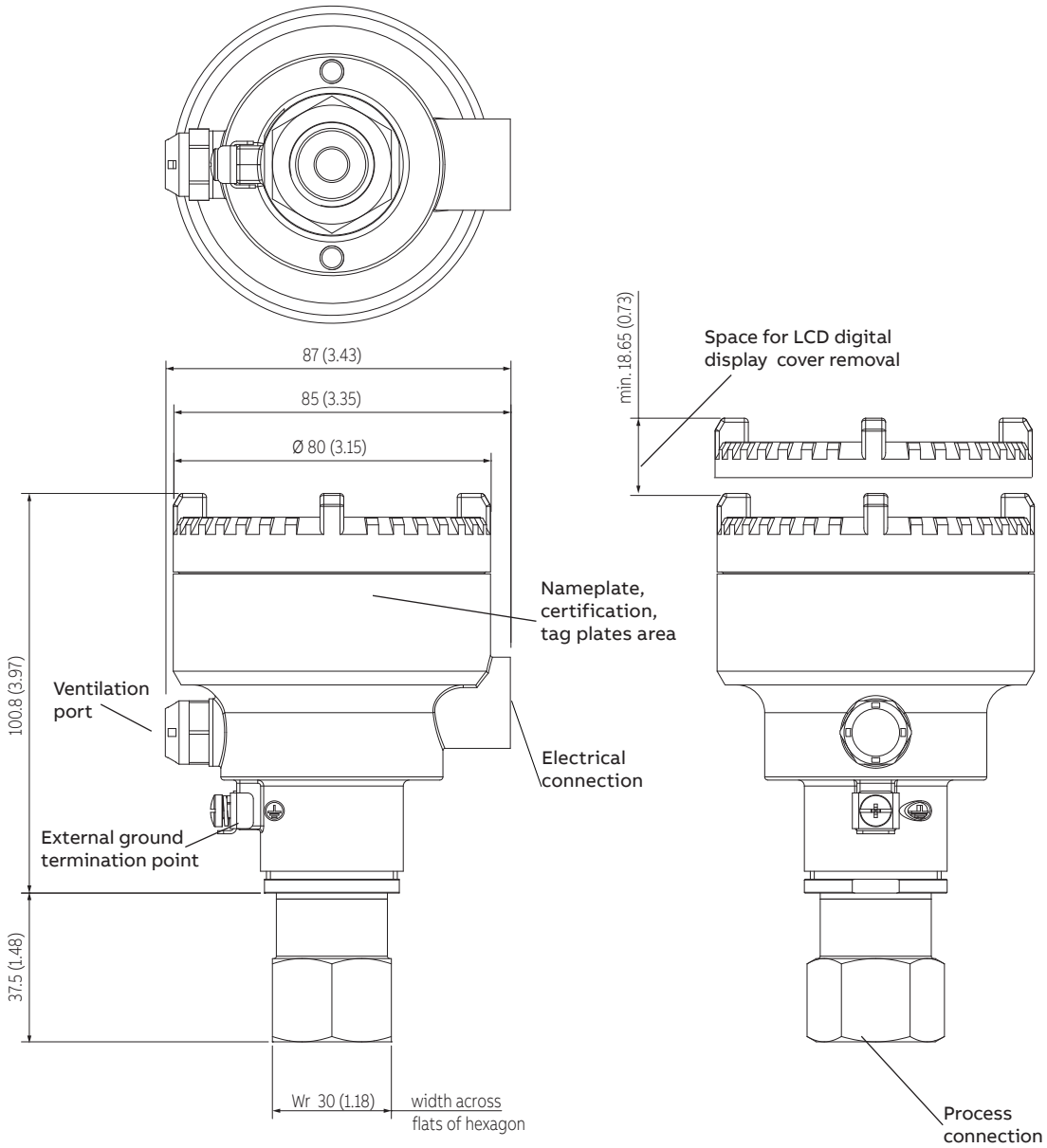

Figure 1 Transmitter with 1/2 in NPT female connection and LCD digital display

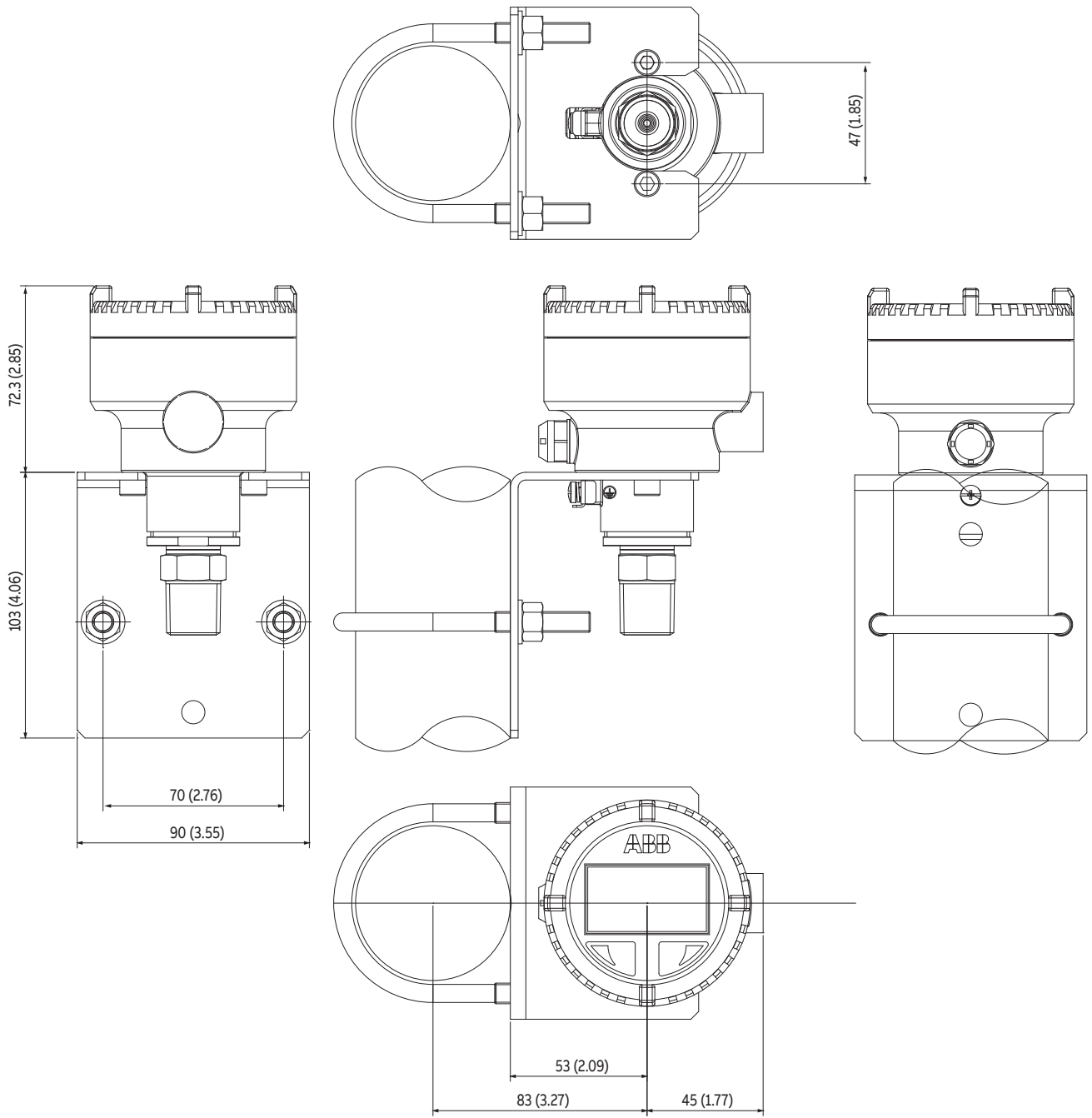

Figure 2 Transmitter with 1/2 in NPT male / 1/4 in NPT female connection on bracket

...Mounting dimensions

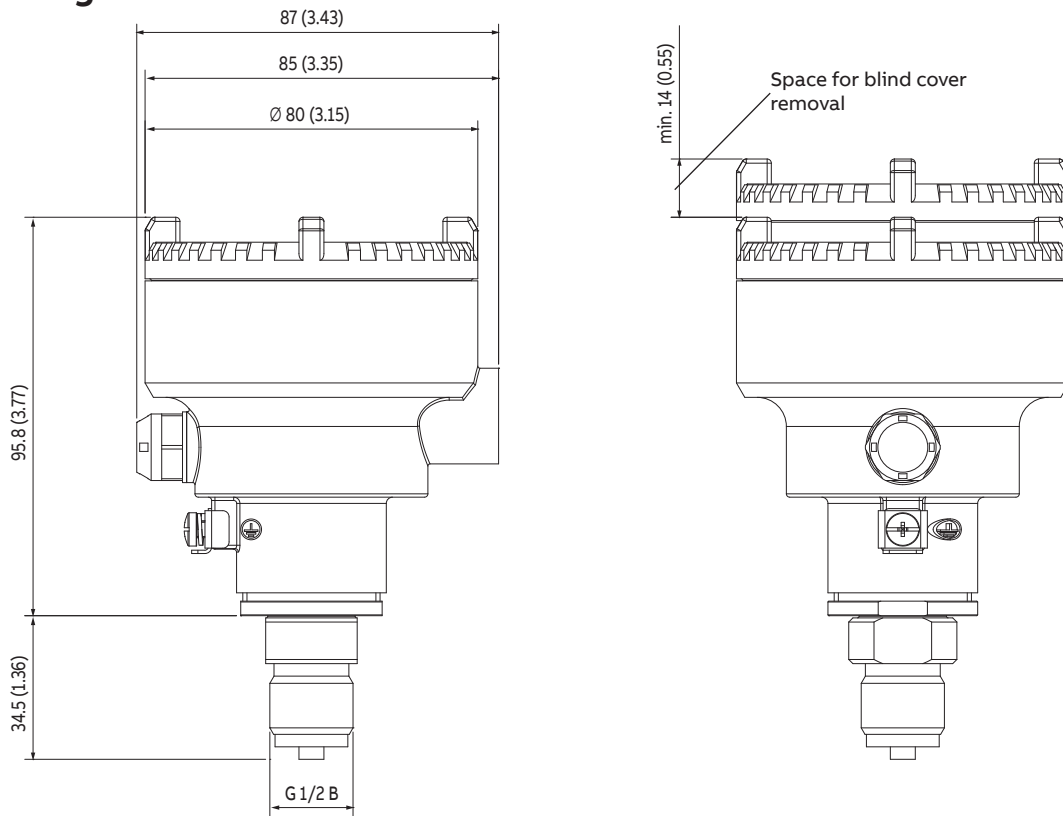

Figure 3 Transmitter with DIN-EN837-1 G 1/2 B connection

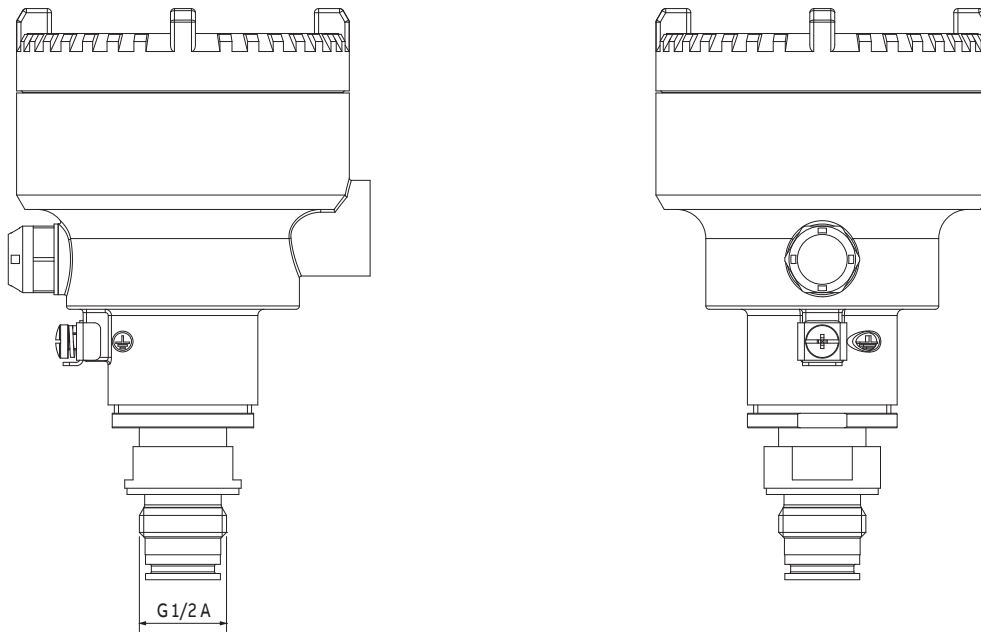

Figure 4 Transmitter with front bonded diaphragm connection

Electrical connections

HART version

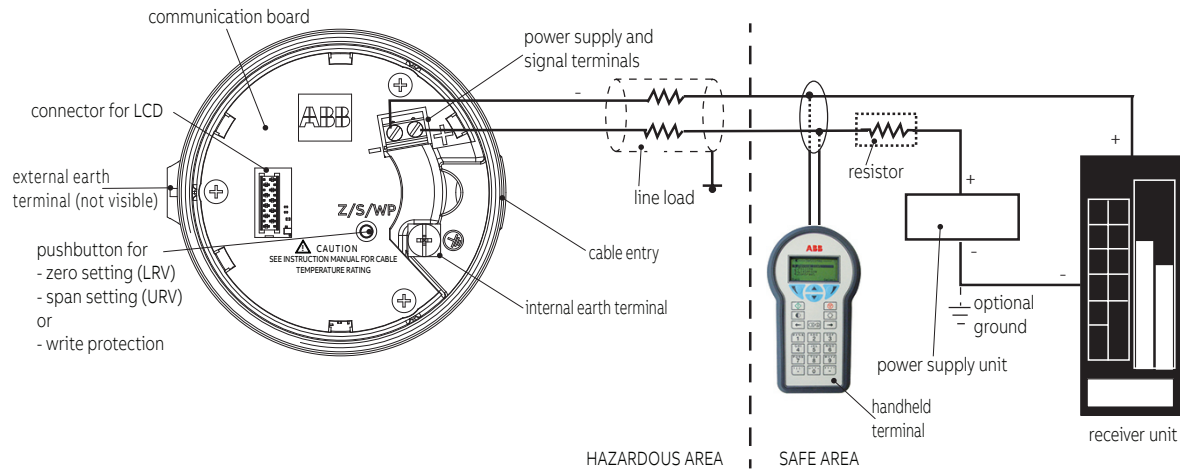

Figure 5 Connections

HART communication requires a minimum loop resistance of 250 ohm. If this is less than 250 ohm, additional resistance should be added.

Additional ordering information model PGS100 Gauge Pressure Transmitters and PAS100 Absolute Pressure Transmitters

Add one or more options code after the basic ordering information to select all required options.

	XX	XX	XXX	XX	XX	XX	XX	XX
Display (see FOOTNOTE)								
Glass touch LCD display with 2-button keypad	D3							
Backlit glass touch LCD display with 2-button keypad	D4							
Extended performances								
± 0.10 % extended base accuracy		E9						
Hazardous area certifications (see relevant paragraph for complete detailed markings)								
ATEX Ex ia and Ex ta/tb	(Note 4)		HAM					
CSA approvals (USA and Canada) IS (Gas and Dust)	(Note 4)		HCM					
IECEX Ex ia and Ex ta/tb	(Note 4)		HJM					
Combined ATEX, CSA approvals (USA and Canada) and IECEX (Gas and Dust)	(Note 4)		HMM					
NEPSI China (Ex ia and Ex iaD / Ex tD)			HMN					
INMETRO (Brazil) Ex ia and Ex ta/tb			HMB					
Approvals								
CSA ordinary location (USA and Canada)	(Note 4)		GO					
Physical application								
Oxygen service cleaning, (only available with inert oil fill) Pmax =10 MPa for Galden; Tmax=60 °C/140 °F or max. working pressure	(Note 5)				P1			
Accessories								
External grounding terminal (fitted as standard if hazardous area certification code Hxx is selected)							AG	
Mounting bracket								
Universal for pipe or wall mounting / AISI 304 ss (1.4301)								BU
Software application								
Calibration to specified measuring span and/or tag number (and printed on plastic label)	(Note 6)							SC
Alarm setting to low current of 3.6 mA								SA
Digital access diagnostics (requires backlit LCD display code D4)								SD

NOTE - Refer to hazardous atmospheres paragraph for compliance of digital display

...Ordering information

...Additional ordering information model PGS100 Gauge Pressure Transmitters and PAS100 Absolute Pressure Transmitters

	XX	XXX	XX
Inspection/compliance certificates			
Inspection certificate EN 10204–3.1 of calibration (5-point) (Note 7)	CF		
Inspection certificate EN 10204–3.1 of cleanliness stage	CC		
Inspection certificate EN 10204–3.1 of helium leakage test of the sensor module	CL		
Inspection certificate EN 10204–3.1 of the pressure test	CH		
Certificate of compliance with the order EN 10204–2.1 of instrument design	CD		
Inspection certificate EN 10204–3.1 of process wetted parts	CM		
Certificate of compliance with the order EN 10204–2.1 of pressure bearing and wetted parts	CW		
Labels			
Label and display visualization in imperial units (Pressure = inH2O/ psi at 68 °F; Temperature = deg. F)		LTU	
Supplemental wired–on stainless steel plate (4 lines, 32 characters each)		LEW	
Label and display visualization in Chinese		LTS	
Manuals			
German			M1
Italian			M2
Spanish			M3
French			M4
English			M5
Chinese			M6
Portuguese			MA

- Note 1: Only available with Front bonded G 1/2 in process connection code P
- Note 2: For 10000 kPa/100 bar/1450 psi sensor code R, H-Shield is only available with front bonded G 1/2 in process connection code P
- Note 3: Not available with 40 kPa/400 mbar/160 inH2O/300 mmHg sensor code F
- Note 4: Hazardous area certification and CSA / FM ordinary location options are mutually exclusive
- Note 5: Not available with DIN EN 837-1 G 1/2 B process connection code C
- Note 6: Option code SC has to be ordered if 0 to URL calibration record is required
- Note 7: Option code CF provides an inspection certificate of calibration 0 to URL
Option code SC should be also selected if the inspection certificate is required for calibration different from 0 to URL

Standard delivery items (can be differently specified by additional ordering code)

- For general purpose applications (no Ex application certification)
- EPDM O-ring for G 1/2 process connection, flush diaphragm
- No display, no mounting bracket
- Short-form leaflet instruction and labels in English
- Configuration with kPa and deg. C units
- No test, inspection or material traceability certificates

IMPORTANT REMARK FOR ALL MODELS

THE SELECTION OF SUITABLE WETTED PARTS AND FILLING FLUID FOR COMPATIBILITY WITH THE PROCESS MEDIA IS A CUSTOMER’S RESPONSIBILITY, IF NOT OTHERWISE NOTIFIED BEFORE MANUFACTURING.

Notes

Notes

ABB Measurement & Analytics

For your local ABB contact, visit:
www.abb.com/contacts

For more product information, visit:
www.abb.com/pressure

We reserve the right to make technical changes or modify the contents of this document without prior notice. With regard to purchase orders, the agreed particulars shall prevail. ABB does not accept any responsibility whatsoever for potential errors or possible lack of information in this document.

We reserve all rights in this document and in the subject matter and illustrations contained therein. Any reproduction, disclosure to third parties or utilization of its contents – in whole or in parts – is forbidden without prior written consent of ABB.

© Copyright 2021 ABB
All rights reserved