

Installation Instructions For EZ-View® Flow Meter and EZ-View® Flow-Alert™ Flow Meter



FORM # HLIT 300

8635 Washington Avenue • Racine • Wisconsin 53406-3738 USA
TEL 800-HEDLAND • FAX 800-CHK-FLOW

⚠ CAUTION

This product should be installed and serviced by technically qualified personnel trained in maintaining industrial class flow instrumentation and processing equipment.

⚠ CAUTION

Read instructions thoroughly before installing the unit. If you have any questions regarding product installation or maintenance, call your local supplier for more information.

I. INTRODUCTION

The EZ-View series flow meter is a rugged, low-cost direct reading industrial class flow meter that is simple to install. It can be mounted (installed) in any position from vertical to horizontal without costly flow straighteners or other special plumbing. Constructed of high impact polysulfone plastic, the EZ-View product line offers excellent structural integrity and chemical compatibility with a wide range of industrial chemicals.

EZ-View flow meters provide instantaneous, direct-reading flow rate measurement of liquids in closed piping systems. The transparent polysulfone plastic body allows visual inspection of the fluid condition as well as viewing of the internal flow indicator relative to a calibrated flow scale. See Figure 1.

EZ-View meters do not require electrical connections for operation, and provide measurement by creating a predictable differential pressure across a sharp-edged orifice that is located in the piston assembly.

II. OPERATING PRINCIPLE

The EZ-View series flow meter is a piston-type variable area flow meter that uses a sharp-edged annular orifice, formed between an open-centered piston and a tapered metering cone. The piston is held in a "no-flow" position at the base of the cone by a precision retention spring. As flow in the pipe increases, the differential pressure correspondingly increases across the piston orifice, and moves the piston/flow indicator against the spring. The greater the flow rate, the further the piston moves along the tapered metering cone. The flow rate is measured by viewing the red indicator ring, mounted on the piston, relative to a graduated flow scale located on the transparent flow meter body (see Figure 2).

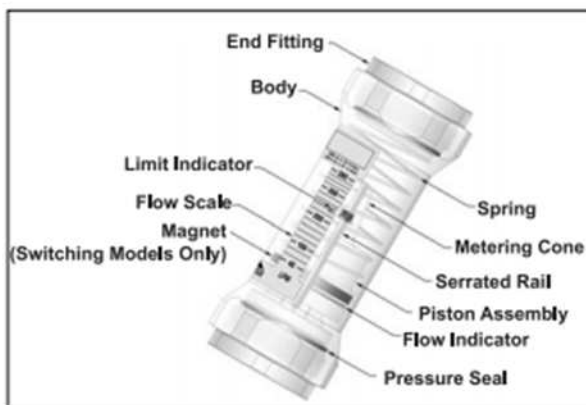

Figure 1. EZ-View Flow Meter

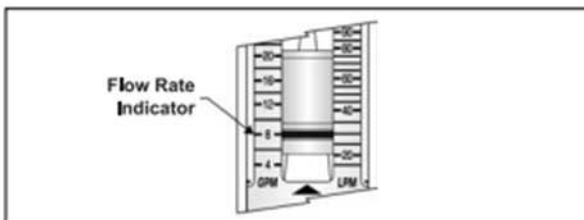

Figure 2. Flow Rate Indicator

The unique design allows the EZ-View meter to be mounted in any orientation—horizontal, vertical, upside down, etc. without sacrificing measurement performance. Flow straighteners, located in the inlet and outlet, allow the flow meter to be less sensitive to turbulent flow conditions. Liquid measurements are provided in GPM (Gallons per Minute) and LPM (Liters per Minute).



EZ-View® Flow Meter and EZ-View® Flow-Alert™ Flow Meter Installation & Maintenance Instructions

III. SPECIFICATIONS

Accuracy

- ± 5% of full scale

Repeatability

- ± 1%

Pressure Rating

- 325 PSI (22.4 bar) Maximum
- Meters with Type 1 PVC fittings subject to normal PVC system ratings

Temperature Range

- 32 °F to 250 °F (0 °C to 121 °C)
- 32 °F to 140 °F (0 °C to 60 °C) for meters with Type 1 PVC fittings

Pressure Drop

- See *Pressure Drop Charts* on page 13.

Fittings/Threads

- NPT ANSI/ASME B1.20.1
- BSPT ISOR7
- BSPP ISO228

Materials (wetted):

- Body Polysulfone

- Piston Polysulfone
- Cone Polysulfone
- Spring T300 Stainless Steel
- Retaining Rings PH15-7MO Stainless Steel
- Seals Buna-N
- Indicator Ring Buna-N
- Limit Indicators Polypropylene
- Magnet Strontium Ferrite (switching units only)
- Fittings C360 Brass
PVC
T303 Stainless Steel

Materials (non-wetted)

- Limit Indicator Polypropylene
- Scale Polyester

Material Compatibility

- See *Fluid Selection Chart* on page 12.

Calibration Fluid

- Oil 0.871 specific gravity
32 cSt viscosity
- Water 1.0 specific gravity
1.0 cSt viscosity

Dimensions

1/2", 3/4" & 1" Sizes					1-1/2" & 2" Sizes				
Size & Type	Material	Connection	Length in. (mm)	Fitting Flats in. (mm)	Size & Type	Material	Connection	Length in. (mm)	Fitting Flats in. (mm)
1/2" NPTF & BSPT	Brass & SS	Female	7.75 (196.8)	1.50 (38.1)	1 1/2" NPTF & BSPP	Brass	Female	8.72 (221.5)	3.00 (76.2)
3/4" NPTF & BSPT	Brass	Male	8.25 (209.5)	1.50 (38.1)	2" NPTF & BSPP	Brass	Female	8.72 (221.5)	3.00 (76.2)
3/4" & 1" Sweat	Brass Brass	Male Sweat	7.75 (196.8)	1.50 (38.1)	2" Socket Weld	PVC	Socket Weld	11.48 (291.6)	N/A
1" NPTF	Polysulfone	Male	5.25 (133.3)	N/A
1" Nominal	PVC	Socket Weld	8.46 (214.9)	1.54 (39.1)
1" NPTF	PVC	Male	8.86 (225.0)	1.50 (38.1)

IV. INSTALLATION

⚠ CAUTION

This unit should be installed and serviced by technically qualified personnel trained in maintaining industrial class flow instrumentation and processing equipment.

Installation Recommendations

The flow meter is a simple device to install. However, the following measures are recommended for reliable, trouble-free operation:

Don't - Allow liquid pipe sealant to come into contact with the plastic flow meter. Most pipe sealants contain solvents that are not compatible with polysulfone plastic and will result in the flow meter body weakening and potentially fracturing under pressure. If a pipe sealant is required, use of Teflon® tape is recommended.

Don't - Install the flow meter in piping systems that are not aligned or properly supported.

Don't - Connect the flow meter male plastic NPT fittings to female metal NPT couplings. Differences in coefficients of expansion between metals and plastics can cause the plastic flow meter body to crack. Utilize a female-to-female plastic pipe coupling to connect metal pipe to the plastic flow meter.

Don't - Use pipe wrenches on the flow meter body. To avoid scarring or otherwise damaging the external surface, use an open-end wrench on the integral hex flats during installation.

Don't - Subject the flow meter to back pressure or back flow. The flow meter will operate as a "leaky" check valve when subjected to reverse flow, but can be damaged if the reverse hydraulic horsepower is too great.

Don't - Install the flow meter on systems with large degrees of particulate contamination. Minimum filtration of 200 mesh (74 micron) is recommended for trouble-free operation.

Don't - Install O-ring seals that have not been lubricated.

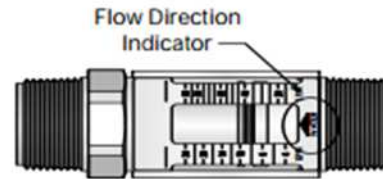

Figure 3. Flow Direction Indicator

Piping (Plumbing)

⚠ CAUTION

To avoid unnecessary pipe flexing that could cause structural stress on the flow meter body, independent support located as near as possible to the inlet and outlet of the meter should be used to isolate the meter from the piping system. Failure to provide this support could reduce the life of the meter.

1. Piping should be properly aligned with the meter inlet and outlet to minimize structural stress on the plastic meter body. Special attention should be given to this effort if higher operational pressures and/or temperatures are anticipated. Piping should be firmly supported by external mounting brackets, both upstream and downstream from the meter to avoid any pipe flexing that could reduce the life of the meter.
2. If the flow meter inlet or outlet are to be rigidly mounted, and the opposing port is to be connected to a flexible hose, the end connected to the flexible hose **MUST** be rigidly mounted.
3. This unique design does not require special plumbing or accessories to stabilize turbulent flow. Flow meters can be installed immediately adjacent to 90° elbows or other components, providing system design flexibility.
4. A 200 mesh (74 micron) or better filtration is required to assure reliable performance.

Flow Direction

These meters only accept flow in one direction. Make sure to align the Flow Arrow, located on the bottom of the meter's flow scale, in the same direction as the anticipated line flow. (See Figure 3).

Mounting Orientation

The meter can be installed to operate in any position.

H621-XXX 1" NPT Models (See Figure 4)

1. Apply a single layer of Teflon® tape to the male NPT threads of the flow meter.
2. Thread the flow meter inlet into a 1" NPT plastic, female pipe coupling.
3. Thread the flow meter and coupling onto the inlet pipe and hand tighten. Make sure the flow direction arrow on the flow meter corresponds with the system flow direction (see Figure 3 on page 3).
4. Place an open-end wrench on the flow meter body hex and place a pipe wrench on the metal mating pipe. Tighten until snug. **DO NOT** overtighten. Make sure the flow meter scale is oriented for convenient viewing. **DO NOT** back off/unscrew fittings to rotate scale for better viewing.
5. Thread a 1" NPT plastic pipe coupling to the outlet connection of the flow meter. Stack a pipe nipple and half of a pipe union onto the pipe coupling. Tighten the assembly as required.
6. Install the other half of the pipe union to the outlet pipe and connect the union halves together.
7. Piping should be supported and aligned properly to avoid placing stress on the flow meter body.
8. Slide the limit indicators to point to appropriate positions on the flow meter scale. To remove the limit indicators, slide them fully towards the flow meter outlet.

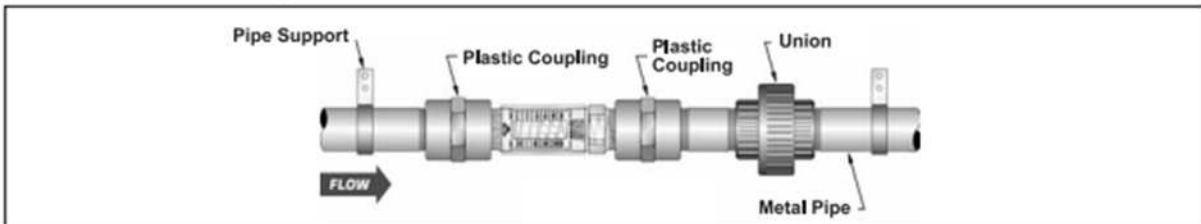

Figure 4. Model H621-XXX 1" NPT Models Installation

H628-XXX 1" and H619-XXX 2" PVC with Socket Weld Models (See Figure 5)

1. Remove the two end fittings from the flow meter. Lubricate the O-rings and install the fittings onto the flow meter.
2. Prepare the flow meter PVC fittings and PVC pipe couplings with PVC cleaner/solvent.
3. Apply a thin layer of PVC glue to the PVC flow meter fittings. Orient the meter during curing to ensure that excessive glue will not run into the flow meter internal components. Connect all PVC glue joints by inserting the pipes fully into their mating components and twisting 1/8 turn to guarantee adhesion. Allow sufficient drying time.
4. Using the method outlined in steps 2 & 3, apply 1/2 of the PVC union to the flow meter outlet fitting.
5. Install the other 1/2 PVC pipe union to the outlet pipe.
6. Make sure the flow direction arrow on the flow meter corresponds with the system flow direction (see Figure 3 on page 3). Lubricate the union O-ring and connect the union together.
7. Piping should be supported and aligned properly to avoid placing stress on the flow meter body.
8. Slide the limit indicators to point to appropriate positions on the flow meter scale. To remove the limit indicators, slide them fully towards the flow meter outlet.

Note: To replace meter body order P.N. H622-XXX

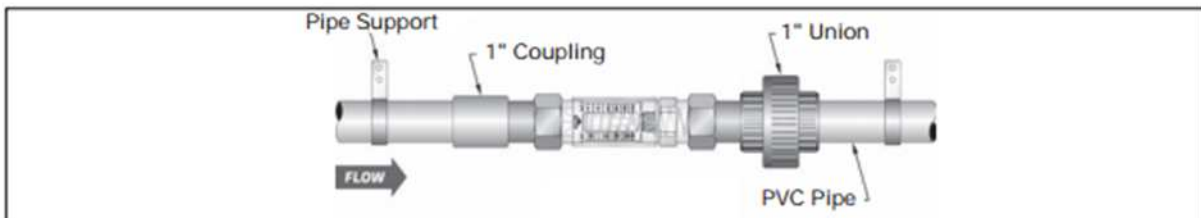

Figure 5. Model H628-XXX 1" & H619-XXX 2" PVC Socket Weld Models Installation

H620-XXX Brass Sweat Fitting Models (See Figure 6)

1. Remove both brass fittings from the flow meter inlet and outlet. Remove O-rings from the fittings.
2. Apply solder flux to the flow meter brass fittings and mating pipe surfaces.
3. Place the brass hex coupler onto the pipe with the threads facing the flow meter. Slide the brass sweat fitting onto the prepared pipe.
4. Sweat the fitting onto the pipe. **DO NOT** apply heat to the brass flow meter fitting with the plastic flow meter body or seals attached to the fitting.
5. Repeat steps 3 & 4 for the other flow meter fitting. Allow fittings to cool.
6. Lubricate the two O-rings removed in step 1. Place the O-rings onto the brass fittings.
7. Place the flow meter in between the two installed brass fittings. Make sure the flow direction arrow on the flow meter corresponds with the system flow direction (see Figure 3 on page 3). Thread the two brass hex couplers into the flow meter body.
8. Rotate the flow meter body so the scale can be conveniently viewed. Tighten the hex couplers. Typically, only hand tightening is required.
9. Piping should be supported and aligned properly to avoid placing stress on the flow meter body.
8. Slide the limit indicators to point to appropriate positions on the flow meter scale. To remove the limit indicators, slide them fully towards the flow meter outlet.

Note: To replace meter body order P.N. H622-XXX

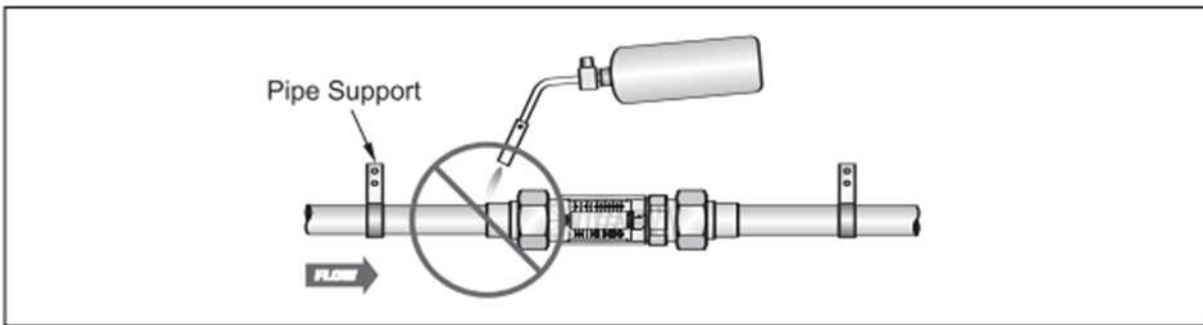

Figure 6. Model H620-XXX Brass Sweat Fitting Models Installation

All Models with Male, Metal or PVC, Threaded, End Fittings (See Figure 7 on page 6)

1. Remove both fittings from the flow meter inlet and outlet. Remove O-rings from the fittings.
2. Apply Teflon® tape to the male pipe thread connections.
3. Place the brass or stainless steel hex coupler onto the pipe with the threads facing the flow meter.
4. Thread the flow meter fittings onto the mating pipe.
5. Tighten fittings by placing an open-end wrench onto the fitting and a pipe wrench onto the mating pipe.
6. Repeat steps 3-5 for the other flow meter fitting.
7. Lubricate the two O-rings removed in step 1. Place the O-rings onto the threaded fittings.
8. Place the flow meter between the two installed fittings. Make sure the flow direction arrow on the flow meter corresponds with the system flow direction (see Figure 3 on page 3). Thread the two hex couplers onto the flow meter body.
9. Rotate the flow meter body such that the scale can be conveniently viewed. Tighten hex couplers. Typically, only hand tightening is required.
10. Piping should be supported and aligned properly to avoid placing stress on the flow meter body.
11. Slide the limit indicators to point to appropriate positions on the flow meter scale. To remove the limit indicators, slide them fully towards the flow meter outlet.

Note: To replace meter body order P.N. H622-XXX

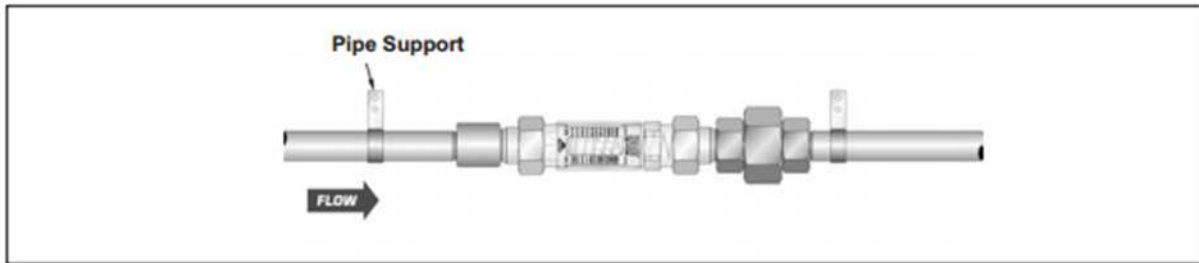

Figure 7. All Models w/Male, Metal, Threaded, End Fittings Installation

All Models with Female, Metal, Threaded, End Fittings (See Figure 8)

1. Apply Teflon® tape to the male pipe thread connections.
2. Thread the inlet of the flow meter onto the appropriate pipe connection. Make sure the flow direction arrow on the flow meter corresponds with the system flow direction (see Figure 3 on page 3).
3. Tighten flow meter connection by placing an open-end wrench on the flow meter metal connection adjacent to the pipe that is being attached. Tighten until snug. Make sure flow meter scale is oriented for convenient viewing. **DO NOT** overtighten. **DO NOT** back off/unscrew to rotate scale for better viewing.

⚠ CAUTION

Do not tighten the flow meter by wrenching from the opposite fitting, as the meter body could crack.

4. Install a union fitting at the outlet end of the flow meter.
5. Piping should be supported and aligned properly to avoid placing stress on the flow meter body.
6. Slide the limit indicators to point to appropriate positions on the flow meter scale. To remove the limit indicators, slide them fully towards the flow meter outlet.

Note: To replace meter body order P.N. H622-XXX



Figure 8. All Models w/Female, Metal, Threaded, End Fittings Installation

V. FLOW-ALERT SWITCH OPTIONS

NOTE: All Flow-Alert switches are magnetically triggered. It is not possible to add a switch to the basic meter if it was not originally ordered with the switching magnet.

Flow-Alert Latching Limit Switch

The AC and DC powered Flow-Alert modules consist of a relay circuit housed in a sealed plastic enclosure. The modules have a normally open, dry relay contact that can be used to directly control alarms, warning lights, relays, or interface to a PLC. The relay will be

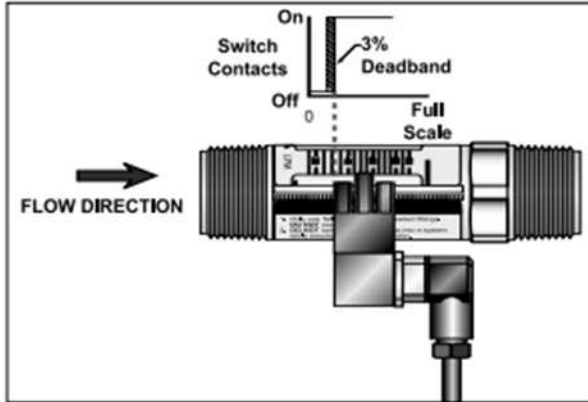

Figure 9. Latching Switches

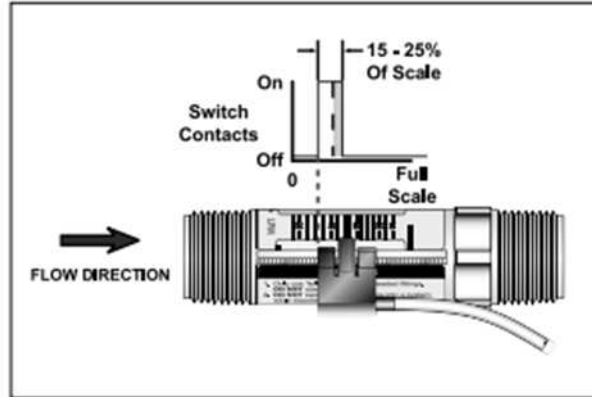

Figure 10. Reed Switches

latched on as the magnet inside the flow meter passes by the module, and remain latched on until the magnet passes in the other direction, or power is interrupted (see Figure 9). The setpoint is adjustable from 0-100% of full scale. Flow meters can be equipped with one latching limit switch, either AC or DC.

Flow-Alert Reed Limit Switch

The reed switch Flow-Alert modules are available in three forms: Form A (normally open), Form B (normally closed), and Form C (single-pole, double throw).

Reed switches are housed in a sealed plastic enclosure for environmental protection. The reed switch modules do not provide a latching function like the AC and DC powered units. When the magnet inside the flow meter comes within proximity of the module, the reed switch will change state (see Figure 10). The setpoint is adjustable from 0-100% of full scale. Two reed switch Flow Alerts may be installed on a single flow meter but one must be set for activation on increasing flow and the second must be set for activation on decreasing flow.

Switch Specifications

Specifications	AC Latching	DC Latching	Specifications	Reed Switch Form-A (NO)	Reed Switch Form-B (NC)	Reed Switch Form-C (SPDT)
Operating Voltage	115 VAC ± 10%	10-30 VDC		N/A	N/A	N/A
Operating Current	25 mA maximum			N/A	N/A	N/A
Contact Rating	1A @ 30 VDC 0.5A @ 125 VAC Resistive Load		Watts Max Voltage Max Current Max	15 200 1A	5 175 25A	5 175 25A
Operating Temperature	32°-158°F (0°-70°C)			32°-250°F (0°-121°C)		
Cable	Not Included N/A			3 ft, 24 AWG 2 Conductor PVC Jacket	3 ft, 20 AWG 2 Conductor PVC Jacket	3 ft, 24 AWG 3 Conductor PVC Jacket
Certification	NA			CE		
Enclosure Rating	NEMA 12 & 13 (IP65)					

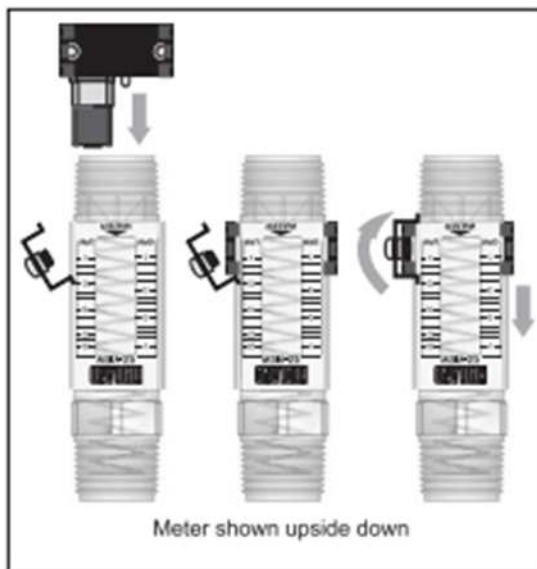

Figure 11. Latching Switch Installation

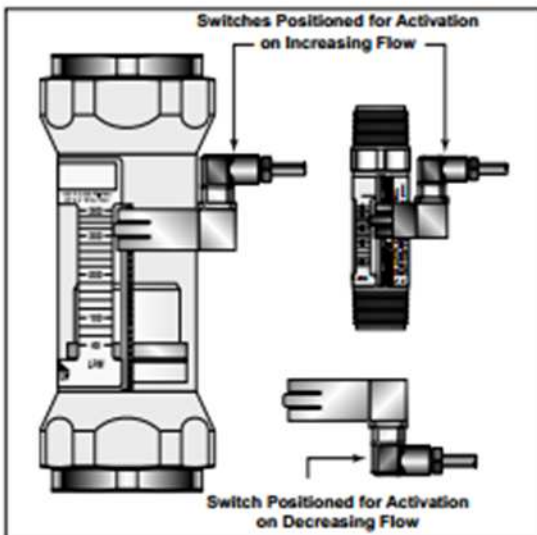

Figure 12. Latching Switch Installation

Flow-Alert Latching Switch Installation, Operation and Adjustment

1. Install one end of the vibration locking kit onto the LPM side of the meters serrated rail as shown in Figure 11. Install the switch by placing the adjustment arms over the serrated rail from the inlet end of the 1/2", 3/4" and 1" meters, or the outlet end of the 1 1/2" or 2" meters. The direction of the connector and cable assembly indicates whether the switch will activate on increasing flow (connector and cable pointing up), or on decreasing flow (connector and cable pointing down). See Figure 12. Secure the other end of the vibration locking kit and tighten after positioning.
2. The connector has four solder lugs labeled 1, 2, 3 and 4. Soldering wires to the terminals first requires disassembly of the connector as shown in Figure 13. The specific wiring pinouts for each style latching switch are shown in Figure 14.
NOTE: Before reassembly, it is recommended to label each wire with the corresponding lug position.
3. After securing wires to solder lugs, determine which direction the body of the connector should face. Before snapping the connector into place, refer to Figure 15.
4. After selecting direction A, B or C, snap connector back together, pull the excess wire out of the strain relief, then tighten the strain relief nut. Plug the connector into the switch module and secure with the screw provided.

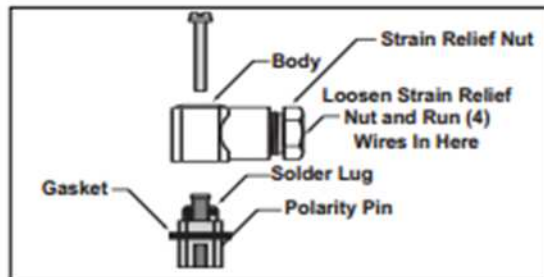

Figure 13. Latching Switch Installation

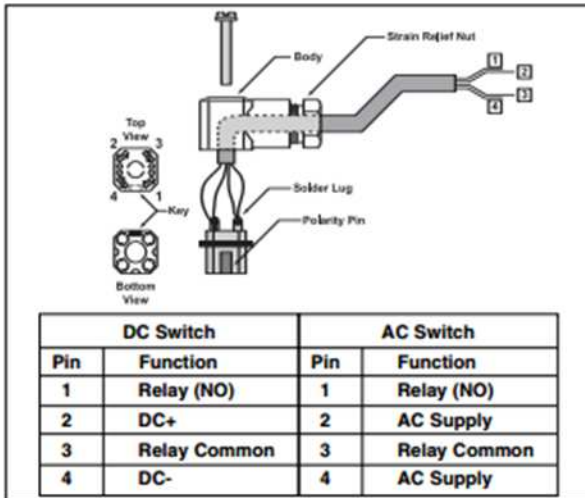

Figure 14. Latching Switch Installation

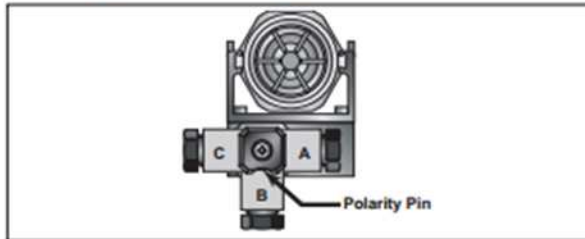

Figure 15. Polarity Pin

Flow-Alert Latching Switch AC Wiring Configurations

WARNING
All wiring should be made in accordance with the National Electrical Code and must conform to any applicable state and local codes.

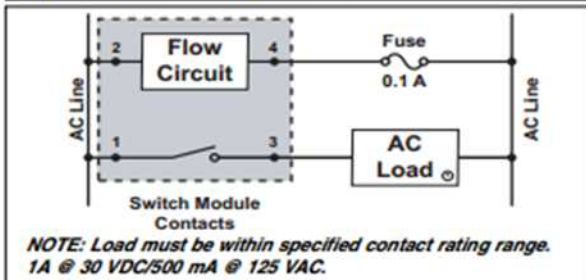

Figure 16. AC Conventional Connection

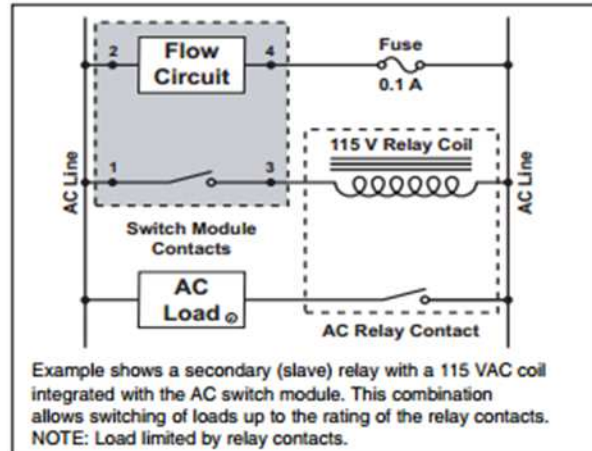

Figure 17. AC Conventional Secondary Connections

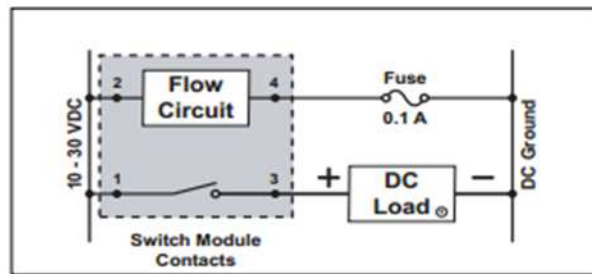

Figure 18. DC Conventional Connection

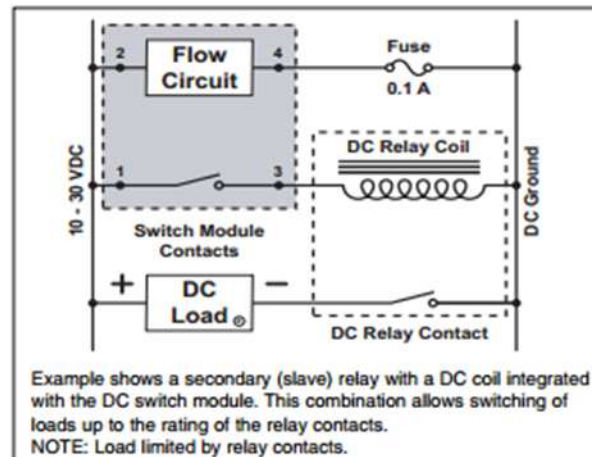

Figure 19. DC Conventional Secondary Connection

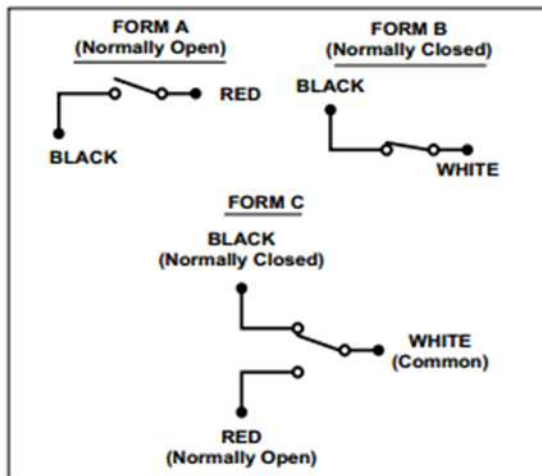

Figure 20. Form A, B & C

Flow-Alert Reed Switch Installation

1. Install the switch on the flow meter by placing the adjustment arm over the serrated rail from the inlet end of the 1/2", 3/4", and 1" meters, or the outlet end of the 1 1/2" and 2" meters. Each meter will accept up to two reed switches and the switch(es) for 1/2", 3/4" and 1" meters must be installed before the meter is plumbed into the system.
2. Flow-Alert reed switches are available in three configurations: Form A (normally open), Form B (normally closed), and Form C (SPDT). Wire color codes and switch configurations are shown in Figure 20.

Flow-Alert Reed Switch Adjustment

After the flow meter has been installed and the switch wired, the flow rate at which the switch will activate must be adjusted as follows:

1. With fluid running through the meter, gently move the switch adjustment tab(s) outward until the switch body is free to slide up or down on the serrated rail. See Figure 21.
2. Move the switch into position until the switch activates. See Figure 21.
3. Release the switch adjustment tab(s) to set the switch position.

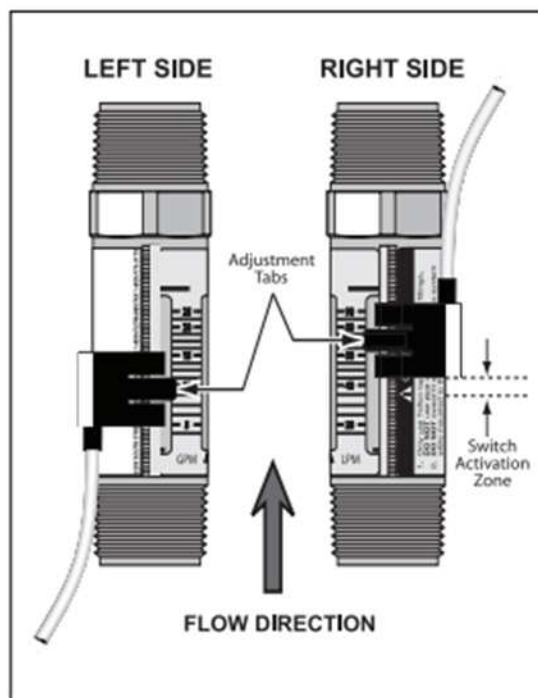

Figure 21. Switch Orientation

⚠ WARNING FAIL-SAFE OPERATION

If the flow meter and switch are to be installed in a critical application, be sure the system is fail-safe. The switch should be wired so any switch failure will stop the system. Failure to fail-safe the system may lead to system damage and/or personal injury.



VI. MAINTENANCE

EZ-View Flow Meters are designed to provide many years of service with little or no maintenance requirements. Periodic cleaning may be required.

- Clean the outside of the flow meter with denatured alcohol or mild detergent and warm water.
- Should the inside of the flow meter become stained, it can be disassembled for cleaning.
- Should the flow meter become jammed with particulate, the meter will require disassembly as described below. The piston assembly should be pushed out from the inlet side to the outlet side. Clean the internal components and reassemble.

Disassembly

NOTE: Models with a 1" body-it is necessary to remove the spring retaining clip (located at the flow meter outlet port).

NOTE: Models with a 2" body can be serviced by removing the two end fittings, then sliding the metering pin out from the inlet, and removing the piston and spring from the outlet.

1. Measure the insertion depth of the retaining ring into the flow meter body with a caliper or other measuring device.
2. Carefully remove the retaining clip with a small, flat-blade screwdriver.
3. Remove the spring and piston assembly.
4. Clean the inside of the flow meter body and piston assembly with denatured alcohol or mild detergent and water.
5. Reassemble the meter in reverse order of disassembly. Install the retaining ring to the depth measured in step 1. Use a deep socket of approximately 0.9" diameter and hand pressure to install the retaining ring.

VII. APPENDIX

Fluid Correction

STANDARD FLOW SCALES

Standard liquid flow scales are calibrated in GPM (Gallons per Minute) and LPM (Liters per Minute) at 0.876 specific gravity for petroleum-based fluids, and 1.0 specific gravity for water and water-based fluids.

For field conversion of the standard scale to other fluids, see *Density Effect* below.

SPECIAL FLOW SCALES

Special scales are available for liquids in any measurement unit, and other fluid viscosities and/or specific gravities.

VISCOSITY EFFECT (SUS/cSt)

The design utilizes a sharp-edged orifice and biasing calibration spring that ensures operating stability and accuracy over the wide viscosity range common to many fluids. Generally, high flow models of each meter size provide good accuracy over a viscosity range of 40 to 500 SUS (4.2 to 108 cSt).

DENSITY EFFECT (SPECIFIC GRAVITY)

Any fluid density change from stated standards has a proportional effect on meter accuracy. Special scales can be supplied if actual specific gravity decreases accuracy beyond application limits. Corrections for more or less dense fluids can be made to standard scales using the following correction factor:

$$\sqrt{\frac{1.0}{\text{Specific Gravity}}} \quad \text{for water/water-based meters}$$

$$\sqrt{\frac{0.876}{\text{Specific Gravity}}} \quad \text{for petroleum-based meters.}$$



EZ-View® Flow Meter and EZ-View® Flow-Alert™ Flow Meter Installation & Maintenance Instructions

Fluid Selection Chart				Internal Components				Fittings		
				Specific Gravity	Correction Factor of Std. Scales		Polysulfone	T300 Stainless	Buna N	PH47 MO Stainless
Oil	Water									
Acetic Acid (Air Free)	1.06	0.909	0.971	R	R	C	R	N	R	R
Acetone	0.79	1.053	1.125	N	R	N	R	R	N	R
Alcohol, Butyl (Butanol)	0.83	1.027	1.089	R	R	R	R	C	R	R
Alcohol, Ethyl (Ethanol)	0.83	1.027	1.089	R	R	N	R	C	R	R
Ammonia	0.89	0.992	1.060	R	R	C	R	C	R	R
Benzene	0.69	1.127	1.204	N	N	N	N	R	N	N
Carbon Disulfide	1.26	0.834	0.891	N	R	N	R	N	N	R
Castor Oil	0.97	0.950	1.015	C	C	R	C	R	C	C
Cotton Seed Oil	0.93	0.970	1.037	R	R	R	R	R	N	R
Ethylene Glycol 50/50	1.12	0.884	0.945	R	R	R	R	R	R	R
Freon II	1.46	0.774	0.828	N	R	N	R	R	N	R
Gasoline	0.70	1.119	1.195	R	R	R	R	R	C	R
Glycerin	1.26	0.834	0.891	R	R	R	R	R	R	R
Kerosene	0.82	1.033	1.104	R	R	R	R	R	R	R
Liquid Propane (LPG)	0.51	1.310	1.400	N	R	R	R	R	R	R
Mineral Oil	0.92	0.976	1.042	R	R	R	R	R	R	R
Naphtha	0.76	1.074	1.147	N	R	R	R	N	N	R
Perchloroethylene	1.62	0.735	0.786	N	R	R	R	N	N	R
Petroleum Oil	0.876	1.000	1.068	R	R	R	R	R	R	R
Phosphate Ester	1.18	0.862	0.921	N	R	N	R	R	N	R
Phosphate Ester Base	1.26	0.833	0.891	N	R	N	R	R	N	R
Phosphoric Acid (Air Free)	1.78	0.701	0.749	R	N	C	N	N	R	N
Sea Water	1.03	0.922	0.985	R	N	R	N	N	R	N
Synthetic Petroleum Base	1.00	0.936	1.000	R	R	R	R	C	R	R
Water	1.00	0.936	1.000	R	R	R	R	R	R	R
Water Glycol 50/50	1.07	0.95	0.967	R	R	R	R	R	R	R
Water-in-Oil	0.93	0.970	1.037	R	R	R	R	R	R	R



EZ-View® Flow Meter and EZ-View® Flow-Alert™ Flow Meter Installation & Maintenance Instructions

Pressure Drop Charts

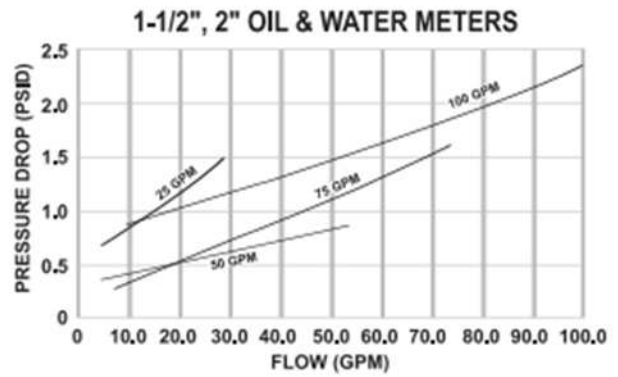
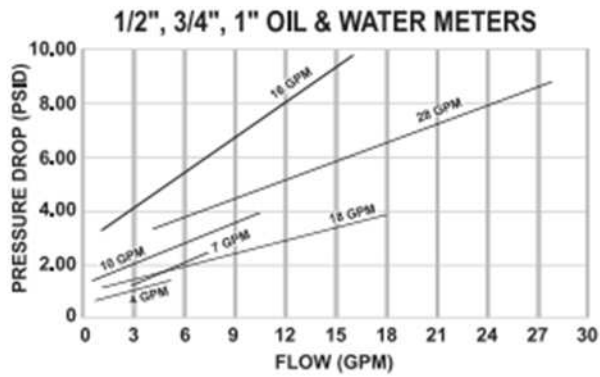



LIMITED WARRANTY and DISCLAIMER

Hedland, Division of Racine Federated Inc. warrants to the end purchaser, for a period of one year from the date of shipment from the factory, that all flow meters manufactured by it are free from defects in materials and workmanship. This warranty does not cover products that have been damaged due to misapplication, abuse, lack of maintenance, or improper installation. Hedland's obligation under this warranty is limited to the repair or replacement of a defective product, at no charge to the end purchaser, if the product is inspected by Hedland and found to be defective. Repair or replacement is at Hedland's discretion. A returned goods authorization number must be obtained from Hedland before any product may be returned for warranty repair or replacement. The product must be thoroughly cleaned and any process chemicals removed before it will be accepted for return.

The purchaser must determine the applicability of the product for its desired use and assumes all risks in connection therewith. Hedland assumes no responsibility or liability for any omissions or errors in connection with the use of its products. Hedland will under no circumstances be liable for any incidental, consequential, contingent or special damages or loss to any person or property arising out of the failure of any product, component or accessory.

All expressed or implied warranties, including **the implied warranty of merchantability and the implied warranty of fitness for a particular purpose or application are expressly disclaimed** and shall not apply to any products sold or services rendered by Hedland.

The above warranty supersedes and is in lieu of all other warranties, either expressed or implied and all other obligations or liabilities. No agent or representative has any authority to alter the terms of this warranty in any way.

