

Product Information FTS-Series
FOOD

Calorimetric Flow Switch

FTS-141, FTS-741

Range of applications

- Monitoring of flowing liquids in pipes
- The monitor can be used to measure liquids that are aqueous (water content $\geq 50\%$), that do not contain oil and that have a medium temperature up to $100\text{ }^{\circ}\text{C}$ ($212\text{ }^{\circ}\text{F}$)

Application examples

- Flow monitoring in pipes from DN 25, e.g., as dry-run protection or for monitoring filters, agitators or cooling loops
- Also suitable for highly pure, aqueous media without particles or solids (e.g. ultra-filtered media, cola)

Hygienic design/Process connection

- Hygienic process connection with CLEANadapt
- Versions compliant to 3-A Standard 74- available
- All wetted materials are FDA-conform
- Sensor completely made of stainless steel
- Complete overview of process connections: see order code
- The Anderson-Negele CLEANadapt system offers a flow-optimized, hygienic and easily sterilizable installation solution for sensors.

Features

- CIP-/SIP-cleaning up to $140\text{ }^{\circ}\text{C}$ ($284\text{ }^{\circ}\text{F}$) for 60 minutes max.
- Calorimetric measurement principle with pulsed heating
- Flow-optimized geometry of sensor tip
- Insensitive to temperature shocks, short response time
- Integrated sensor protection through automated switch-off at over-temperature $T > 100\text{ }^{\circ}\text{C}$ ($212\text{ }^{\circ}\text{F}$)
- Display of flow rate in % of measurement range and signaling of switch output
- Adjustable switch output in % of flow rate
- Behavior of PNP switch output can be changed
- Adjustment of switch output behavior when switching off due to over-temperature $T > 100\text{ }^{\circ}\text{C}$ ($212\text{ }^{\circ}\text{F}$)

Options/Accessories

- Preassembled cable for M12 plug

Communication
 **0/1**
Flow switch FTS-741

Flow switch FTS-141

Functional principle

The functional principle of the FTS calorimetric flow monitor is based on a temperature sensor mounted on the sensor tip (1) that is periodically heated by a heating element (2). When the medium is stationary, a constant temperature difference ΔT arises between the heated and unheated state. When the medium flows, heat energy is withdrawn from the heated temperature sensor and the temperature difference changes in relation to the flow rate.

In contrast to designs with two separate temperature sensors, of which one is constantly being heated, the measuring principle of the FTS with only one sensor and periodic heating has a lower response time due to the optimized heat transfer and lower heat capacity.

The response time is also significantly influenced by the heat conductivity of the medium. In general, the lower the heat conductivity of the medium, the higher the medium flow rate must be for measurement to be possible.

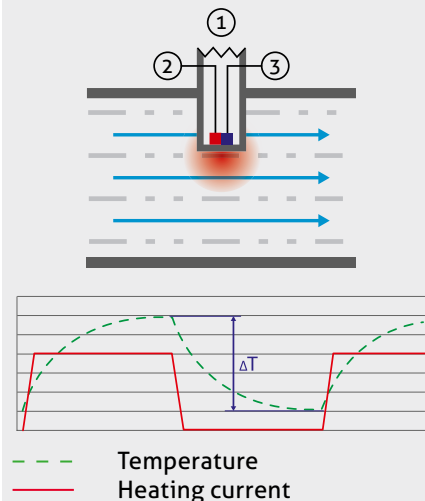
Schematic drawing

Specification		
Process connection	Thread	Hygienic G1/2" CLEANadapt tightening torque max. 20 Nm sizes: 1½", 2"
	Tri-Clamp	
Materials	Sensor head/ metal cap	1.4308 (AISI CF-8)
	Process connection (wetted parts)	1.4404 (AISI 316L)
	Cover (plastic)	Polycarbonate
Temperature ranges	Environment	-20...70 °C (-4...158 °F)
	Process	0...100 °C (32...212 °F)
	CIP/SIP	140 °C (284 °F) (no function) / max. 60 min.
Operating pressure		Max. 10 bar (CLEANadapt) Max. 60 bar (Tri-Clamp)
Protection class		IP 69 K
Measuring range	FTS-141	0,1...2 m/s (6.5 ft/s; 78.7 in/s)
	FTS-741	0,1...3 m/s (9.8 ft/s; 118.1 in/s)
Response time		5 s
Reaction time	For temperature jump	max. 10 s at 40 K
Accuracy*		10 % of full scale
	In nominal width range	DN25...DN100
Switch point	Freely adjustable	
	FTS-141	4...100 % / 0,15...2 m/s (6.5 ft/s)
	FTS-741	4...100 % / 0,15...3 m/s (9.8 ft/s)
	Hysteresis	10 %
Display	Display 0-100 Red LED	In % of measurement range Output switching state
Electrical connection	Cable connection	M12 connector 1.4301 (AISI 304)
	Supply voltage	16...32 V DC
	Current consumption	60 mA (24 V DC) plus output
Output		PNP, max. 200 mA Short-circuit proof and protected against reverse polarity
Weight	FTS-141	410 g
	FTS-741 with Tri-Clamp 1½"	440 g
	FTS-741 with Tri-Clamp 2"	520 g

*) Reference conditions in case of laminar flow profiles: calibration medium is water at ambient temperature.

Measurable media



The following media can be measured: aqueous liquids (water content $\geq 50\%$) and liquids that do not contain oil, such as water, milk, beer, fruit juice, CIP media, etc. Gases, oils and media containing oil cannot be measured with the FTS.

Notice



Flow monitor FTS has an integrated self-protection mechanism that prevents damage:
At medium temperatures over $100\text{ }^{\circ}\text{C}$ ($212\text{ }^{\circ}\text{F}$), the sensor is automatically switched off with a hysteresis of $5\text{ }^{\circ}\text{C}$.
Three lines appear on the indicator.

Intended use



- Not suitable for applications in potentially explosive areas.
- Not suitable for applications in safety-relevant system parts (SIL).

Dimensional drawing FTS-141

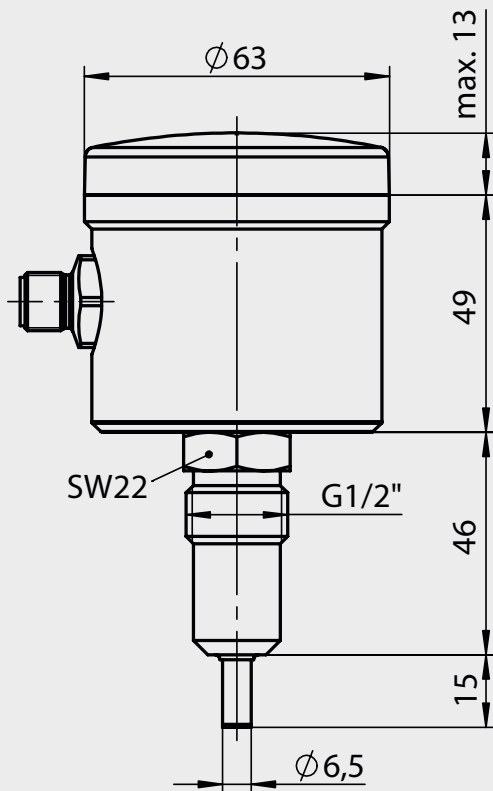

Dimensional drawing FTS-741

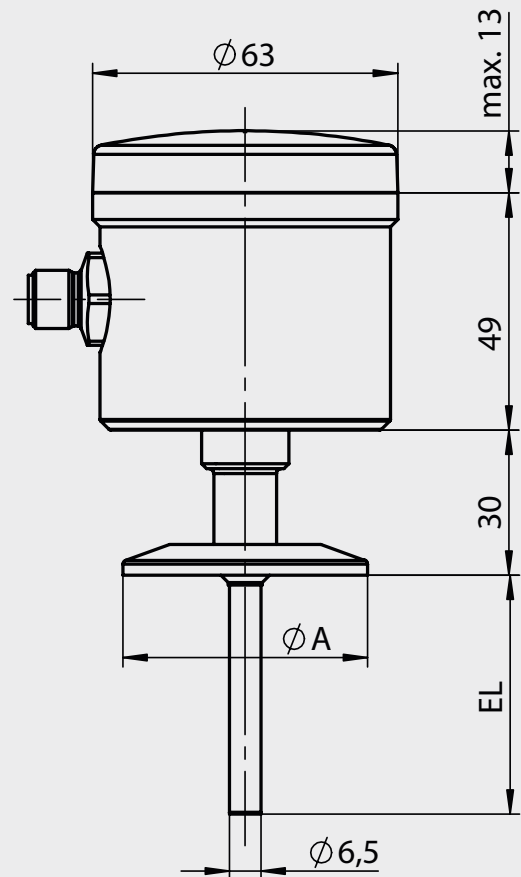

Dimension Table on FTS-741

Order code	Clamp size A [mm / inch]	Immersion length EL [mm / Inch]	Suitable for pipe diameter	Pipe style
FTS-741/C10...	50.5 / 1½"	49 / 1.93	DN 25...40 ISO 14...25 1½"	DIN 11866 series A DIN 11866 series B / ISO 1127 DIN 11866 series C / ASME-BPE
FTS-741/C20...	64 / 2"	59 / 2.32	DN 50 2"	DIN 11866 series A DIN 11866 series C / ASME-BPE

Electrical connection FTS

- 1: + power supply
- 2: Not assigned
- 3: - power supply (GND)
- 4: Switch output active

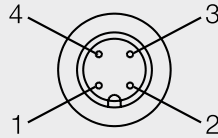

Display view



Operation FTS

1. Startup

- Install the FTS and make the electric connection
- During the initialization phase of 20 s, the device flashes "888"
- At overtemperature $T > 100\text{ }^{\circ}\text{C}$ ($212\text{ }^{\circ}\text{F}$), "---" is displayed
- Display of flow rate as % of measurement range, signaling of switch output with LED
- Factory Setting
 - Switch is activated at a flow rate of 40% of measurement range ($SP = 40$)
 - Definition of switch output: active ($0-C = \text{n.o.}$)
 - The switch output is not switched off at overtemperature $T > 100\text{ }^{\circ}\text{C}$ ($212\text{ }^{\circ}\text{F}$) ($ot0 = \text{off}$)

2. Menu guidance

- Open the operating mode 2x , 2x and 2x
- Select a setting in the sequence "SP" – "0-C" – "ot0" with
- Display the current setting and close with
- Next menu item or close the operating mode

3. Setting the switch point

- Change to the operating mode and select the "SP" setting
- Display and change the current value with 2x
- Increase the flashing value with , select the next position with . The values range is 4...199%.
- Adopt and close the setting with 2x
- Next menu item or close the operating mode

4. Definition of switch output

- Change to the operating mode and select the "0-C" setting with
- Display the current definition with
- Change the switch output between active (normally open) "n.o." or inactive (normally closed) "n.c." with
- Adopt the current value with
- Next menu item or close the operating mode

5. Behavior of the switch output during overtemperature

- Change to the operating mode and select the "ot0" setting with
- Display the current definition with
- The switch output does not switch off when overtemperature is "off" or when overtemperature is "on", toggle with
- Adopt the current value with
- Next menu item or close the operating mode

FTS-741 Setpoint by Line Size and Velocity

Line Size	Velocity m/s (ft/sec)									
	0.3 (1.0)	0.6 (2.0)	0.9 (3.0)	1.2 (4.0)	1.5 (5.0)	1.9 (6.0)	2.1 (7.0)	2.4 (8.0)	2.7 (9.0)	3.0 (10.0)
	Flow rate l/min (gal/min)									
1"	7.2 (1.9)	14.4 (3.8)	21 (5.6)	28 (7.5)	35 (9.4)	43 (11)	50 (13)	57 (15)	64 (17)	72 (19)
1½"	18 (4.6)	36 (9.2)	52 (14)	70 (19)	87 (23)	105 (28)	123 (32)	140 (37)	158 (42)	180 (46)
2"	33 (8.6)	66 (17)	98 (26)	130 (34)	163 (43)	195 (52)	228 (60)	261 (69)	293 (77)	330 (86)
2½"	52 (14)	104 (28)	159 (42)	212 (56)	265 (70)	318 (84)	366 (97)	418 (110)	470 (124)	520 (140)
3"	76 (20)	152 (40)	228 (60)	303 (80)	383 (101)	459 (121)	536 (142)	613 (162)	689 (182)	760 (200)
4"	140 (37)	280 (74)	420 (74)	557 (147)	696 (184)	835 (221)	974 (257)	1113 (294)	1252 (331)	1400 (370)
Setpoint	10	20	30	40	50	60	70	80	90	100

FTS-141 Setpoint by Line Size and Velocity

Line Size	Velocity m/s (ft/sec)					
	0.3 (1.0)	0.6 (2.0)	0.9 (3.0)	1.2 (4.0)	1.5 (5.0)	1.9 (6.0)
	Flow rate l/min (gal/min)					
1"	7.2 (1.9)	14.4 (3.8)	21 (5.6)	28 (7.5)	35 (9.4)	43 (11)
1½"	18 (4.6)	36 (9.2)	52 (14)	70 (19)	87 (23)	105 (28)
2"	33 (8.6)	66 (17)	98 (26)	130 (34)	163 (43)	195 (52)
2½"	52 (14)	104 (28)	159 (42)	212 (56)	265 (70)	318 (84)
3"	76 (20)	152 (40)	228 (60)	303 (80)	383 (101)	459 (121)
4"	140 (37)	280 (74)	420 (74)	557 (147)	696 (184)	835 (221)
Setpoint	15	30	45	60	75	95

Mechanical connection/Installation

- Ensure that the pipe in which the sensor is installed is completely filled with liquid. Installation in a rising pipe is recommended (in which the direction of flow is upward)
- Note the inlet and outlet dimensions (see drawing DN = pipe cross section)

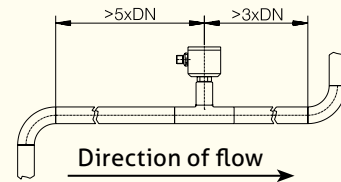

Note on 3-A Sanitary Standard 74-

Information on installation according to 3-A standard is available on our website:
www.anderson-negele.com/3A74.pdf

Click on the PDF icon to download the document.



Pipe T dimensions for FTS-741

Tri-Clamp size [inch]	Pipe [inch]	Pipe [mm]	T-Short Extract	
			B [mm]	L [mm]
1½	1½	38.1 x 1.65	34.9	15.9
2	2	50.8 x 1.65	41.3	15.9
2	2½	63.5 x 1.65	47.6	15.9

Pipe T

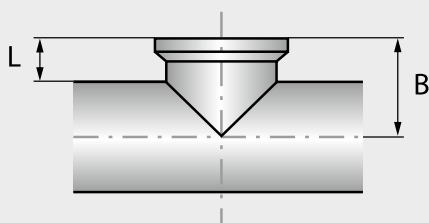

Note

The Flow Switch FTS-741 is specially designed to work with pipe Ts that have a short extract.



Adapter for FTS-141

G1/2"		Adapter for FTS-141	
		EHG	Varivent
Diameter		EHG	Varivent
DN25	1"	EHG-DIN2-25/1/2"	AMV-132/25
DN40	1½"	EHG-DIN2-40/1/2"	AMV-132/40
DN50	2"	EHG-DIN2-50/1/2"	AMV-132/50
DN65	2½"	EHG-DIN2-65/1/2"	AMV-132/65

Transport/storage

- Do not store outside
- Store in an area that is dry and dust-free
- Do not expose to corrosive media
- Protect against solar radiation
- Avoid mechanical shock and vibration
- Storage temperature 0...40 °C (32...104 °F)
- Relative humidity max. 80 %

Standards and guidelines

- Compliance with the applicable regulations and directives is mandatory.

Notice on CE

- Applicable directives:
Electromagnetic Compatibility Directive 2014/30/EU
- Compliance with the applicable EU directives is identified by the CE label on the product.
- The operating company is responsible for complying with the guidelines applicable to the entire installation.

Reshipment

- Sensors and process connection must be clean and must not be contaminated with hazardous media and/or heat-conductive paste. Note the cleaning information!
- To avoid damage of the equipment, use suitable transport packaging only.

Cleaning/maintenance

- When using a pressure washer, do not point the nozzle directly at the electrical connections.

Disposal

- Electrical devices should not be disposed of with household trash. They must be recycled in accordance with national laws and regulations.
- Take the device directly to a specialized recycling company and do not use municipal collection points.

Conversion table m/s to l/min

DN	DN 25	DN 40	DN 50	DN 65	DN 80	DN 100
Flow [m/s]	[l/min]	[l/min]	[l/min]	[l/min]	[l/min]	[l/min]
0.1	2.9	7.5	11.8	19.9	30	47
0.2	5.9	15.1	23.6	39.8	60	94
0.4	11.8	30.1	47.1	79.6	121	188
0.6	17.7	45.2	70.7	119.4	181	283
0.8	23.6	60.3	94.2	159.2	241	377
1.0	29.4	75.4	117.8	199.0	301	471
1.2	35.3	90.4	141.3	238.8	362	565
1.4	41.2	105.5	164.9	278.6	422	659
1.6	47.1	120.6	188.4	318.4	482	754
1.8	53.0	135.6	212.0	358.2	543	848
2.0	58.9	150.7	235.5	398.0	603	942
2.2	64.8	165.8	259.1	437.8	663	1 036
2.4	70.7	180.9	282.6	477.6	723	1 130
2.6	73.6	188.4	294.4	497.5	754	1 178
2.8	82.4	211.0	329.7	557.2	844	1 319
3.0	88.3	226.1	353.3	597.0	904	1 413

Conversion table in/s to gal/min

DN		1"	1½"	2"	3"	4"
Flow [in/s]	[m/s]	[gal/min]	[gal/min]	[gal/min]	[gal/min]	[gal/min]
4.0	0.10	0.82	1.84	3.26	7.34	13.05
8.0	0.20	1.63	3.67	6.53	14.68	26.10
16.0	0.41	3.26	7.34	13.05	29.36	52.20
24.0	0.61	4.89	11.01	19.58	44.05	78.30
32.0	0.81	6.53	14.68	26.10	58.73	104.41
40.0	1.02	8.16	18.35	32.63	73.41	130.51
48.0	1.22	9.79	22.02	39.15	88.09	156.61
56.0	1.42	11.42	25.69	45.68	102.77	182.71
64.0	1.63	13.05	29.36	52.20	117.46	208.81
72.0	1.83	14.68	33.03	58.73	132.14	234.91
80.0	2.03	16.31	36.71	65.25	146.82	261.01
88.0	2.24	17.94	40.38	71.78	161.50	287.12
96.0	2.44	19.58	44.05	78.30	176.18	313.22
104.0	2.64	21.21	47.72	84.83	190.87	339.32
112.0	2.84	22.84	51.39	91.36	205.55	365.42
120.0	3.05	24.47	55.06	97.88	220.23	391.52

Order code CLEANadapt G1/2" process connection

FTS-141 Calorimetric Flow Sensor with switch output, CLEANadapt G1/2" process connection

Cap

- X** Plastic without window
- P** Plastic with control window
- M** Metal without control window
- W** Metal with control window

FTS-141 / X

Order code DIRECTadapt

FTS-741 Calorimetric Flow Sensor with switch output, Tri-Clamp process connection

Process connection (A: 3-A compliant)

- C10** Tri-Clamp 1½" A
- C20** Tri-Clamp 2" A

Cap

- X** Plastic without window
- P** Plastic with control window
- M** Metal without control window
- W** Metal with control window

Surface finish

- XX** 0.8 microns / 0.8 µm

FTS-741 / C20 / X / XX

Accessories

PVC cable with M12 connection made of 1.4305 (AISI 303), IP 69 K, unshielded

- M12-PVC / 4-5 m** PVC cable, 4-pin, length 5 m
- M12-PVC / 4-10 m** PVC cable, 4-pin, length 10 m
- M12-PVC / 4-25 m** PVC cable, 4-pin, length 25 m

PVC cable with M12 connection, nickel-plated brass, IP 67, shielded

- M12-PVC / 4G-5 m** PVC cable, 4-pin, length 5 m
- M12-PVC / 4G-10 m** PVC cable, 4-pin, length 10 m
- M12-PVC / 4G-25 m** PVC cable, 4-pin, length 25 m



CERT / 2.2 / FTS

factory certificate 2.2 acc. to EN10204 (product-contacting surface only)

PVC cable with M12 connection



Accessories for FTS-741 (not part of standard scope of supply)

Tri-Clamp size	Clamp size A [mm] (see page 3)		
		Clamp ring Tri-Clamp	Sealing ring Tri-Clamp (EPDM)
1"	50.5	SRC-25	DRC-1"
2"	64.0	SRC-50	DRC-50