

BlackStone Chemical Dosing Pumps



Versatility

BlackStone pumps have been designed to meet the ever changing needs of industry. With their broad, flat base and mounting holes for tank, shelf or floor mounting (horizontal), the pumps can be easily mounted anywhere in your plant. The rear of the pump housing also provides mounting holes to facilitate vertical mounting: wall, tank or machine. Since the pump valve assembly and controls for the unit are located on the front of the pump, there is never a problem with installation or flow adjustments.

Simple Operation

BlackStone pumps are equipped with a single control for pump output. The external flow rate control (potentiometer) on the face of the pump allows you to adjust the percentage of flow from 0 to 100% of the pump's rated capacity. This feature eliminates the need to worry about stroke lengths and power settings. An LED indicator lights up each time a stroke begins, allowing the user to assess the stroke rate from a distance.

High Quality Materials

BlackStone pumps have been manufactured with the highest level of mechanical precision from materials chosen for their inherent ability to resist the effects of aggressive chemicals. When you select a Blackstone pump, you are eliminating the time consuming effort involved in picking the right material for your application. Blackstone pumps are supplied with the highest quality material as standard equipment—not optional. The diaphragm utilizes one-piece construction of PTFE, which unlike conventional laminated diaphragms, will stand up to the test of time and wear. Ball valves are constructed in glass.

The pumphead and O-rings are made of PVDF, PTFE and FPM/FKM which offer unsurpassed resistance. The chemical resistance chart (right) shows how well PVDF and PTFE stand up to some of the most aggressive chemicals.



Chemical Resistance Guide*

Chemical Resistance Guide*	PVC	PP	Hypalon	FPM/FKM	PVDF	PTFE
Acetic Acid, 80%	D	B	A	E	A	A
Bleach	A	B	A	A	A	B
Citric Acid	A	A	A	A	A	A
Copper Cyanide	A	A	X	B	A	A
Copper Sulfate	A	A	B	B	A	A
Ferric Chloride	A	A	B	B	A	A
Ferric Sulfate	A	A	B	B	A	A
Hydrazine	X	X	B	B	A	A
Hydrochloric Acid (concentrated)	A	A	B	B	A	A
Hydrochloric Acid (diluted)	A	A	B	B	A	A
Hydrofluoric Acid (diluted)	D	B	D	A	A	A
Hydrogen Sulfide	C	A	B	B	A	A
Magnesium Nitrate	A	A	A	A	A	A
Magnesium Sulfate	A	A	A	A	A	A
Nitric Acid, 50%	A	C	E	A	A	A
Phosphoric Acid	B	B	A	B	A	A
Plating Baths	A	A	C	A	A	A
Potassium Cyanide	A	A	B	B	A	A
Potassium Nitrate	A	A	B	B	A	A
Propyl Alcohol	C	X	B	B	A	A
Soaps	A	A	B	B	A	A
Sodium Bicarbonate	A	A	A	A	A	A
Sodium Bisulfite	A	A	A	A	A	A
Sodium Hydroxide, 50%	A	A	B	E	A	A
Sodium Hypochlorite, 18%	A	A	A	D	A	A
Sulfuric Acid (concentrated)	A	A	B	A	A	A
Tanning Reagents	A	A	A	X	A	A
Trichlorethane	E	C	E	A	A	A

* PARTIAL LISTING

Symbol Key

A - Excellent B - Good C - Fair D - Acceptable (limited use) E - Not recommended X - Unknown

BL Series Dosing Pumps

BlackStone's positive displacement solenoid driven pumps use a minimum number of moving parts, therefore reducing the chance of mechanical failure. Part wear and oiling associated with motor driven pumps (ball-bearings, gear drives and cams) are not a concern with these pumps. Blackstone pumps are more accurate than standard pumps due to the positive displacement design ensuring each stroke is identical to the strokes before and after it, thus keeping the flow rate consistent.

A wide range of BlackStone pumps with different dosing capacities are available for your specific dosing needs. Each pump is supplied with discharge and suction valves.

Part Number	Max Output	Rated Pressure	Dosing Frequency strokes/min
With Large Diaphragm			
BL 20	18.3 lph (4.8 gph)	0.5 bar (7.4 psi)	120
BL 15	15.2 lph (4.0 gph)	1 bar (14.5 psi)	120
BL 10	10.8 lph (2.9 gph)	3 bar (43.5 psi)	120
BL 7	7.6 lph (2.0 gph)	3 bar (43.5 psi)	120
With Small Diaphragm			
BL 5	5.0 lph (1.3 gph)	7 bar (101.5 psi)	120
BL 3	2.9 lph (0.8 gph)	8 bar (116 psi)	120
BL 1.5	1.5 lph (0.4 gph)	13 bar (188.5 psi)	120

SPECIFICATIONS	BL Series
Max Output	see table above
Pump Casing	fiber-reinforced polypropylene
Materials	pumphead in PVDF, diaphragm in PTFE, glass ball valves and O-rings in FPM/FKM, polyethylene 5 x 8 mm tubing
Self-priming	max height: 1.5 m (5 feet)
Power Supply	110/115 VAC or 220/240 VAC, 50/60Hz
Max Power Consumption	approximately 200 W
Protection	IP65
Environment	0 to 50°C (32 to 122°F); RH max 95% non-condensing
Dimensions	194 x 165 x 121 mm (7.6 x 6.5 x 4.8")
Weight	approx. 3 kg (6.6 lb.)

ORDERING INFORMATION*

BL 1.5-1	1.5 LPH flow rate
BL 1.5-2	1.5 LPH flow rate
BL 3-1	2.9 LPH flow rate
BL 3-2	2.9 LPH flow rate
BL 5-1	5.0 LPH flow rate
BL 5-2	5.0 LPH flow rate
BL 7-1	7.6 LPH flow rate
BL 7-2	7.6 LPH flow rate
BL 10-1	10.8 LPH flow rate
BL 10-2	10.8 LPH flow rate
BL 15-1	15.2 LPH flow rate
BL 15-2	15.2 LPH flow rate
BL 20-1	18.3 LPH flow rate
BL 20-2	18.3 LPH flow rate

ACCESSORIES

HI 721004**	Injection valve assembly
HI 721005**	Foot valve assembly
HI 721101	Pumphead, O-ring, screws and washer

HI 721102	Discharge valve assembly
HI 721103	Suction valve assembly
HI 721008	Ceramic weight (4)
HI 720011D	Magnet and coil for BL pumps (230VAC)
HI 720011U	Magnet and coil for BL pumps (115VAC)
HI 720025	Pump body
HI 720034	Magnet pump head assembly for BL pumps
HI 721001	Complete pumphead with valves
HI 72001	Tube nut, 5 x 8 mm dia. (100 pcs)
HI 721009	Diaphragm
HI 721010	PTFE coated O-ring for pump head
HI 721011	Aluminum piston, insulation disk, washer and springs replacement kit for BL pump
HI 721013	Piston set for BL pump
HI 721014	Bottom housing and housing seal
HI 721104	Small diaphragm for BL pumps
HI 721105	BlackStone spare pump head
HI 721106	BlackStone pump head assembly

Rugged Design

Blackstone pumps are completely sealed during assembly and offer IP65 protection against splashes and spills providing excellent protection even in hostile environments. The fiber-reinforced polypropylene housing stands up to aggressive chemicals while offering superior strength under tough industrial conditions.

Typical Installations

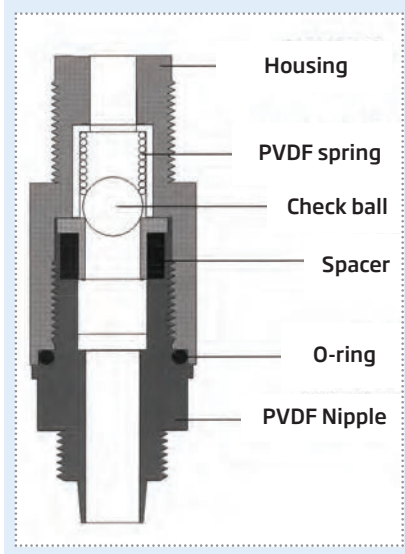
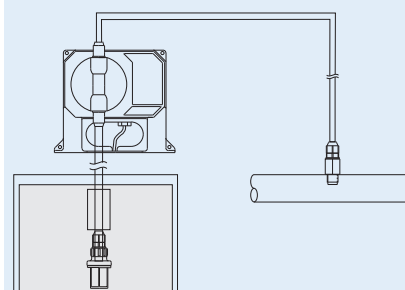
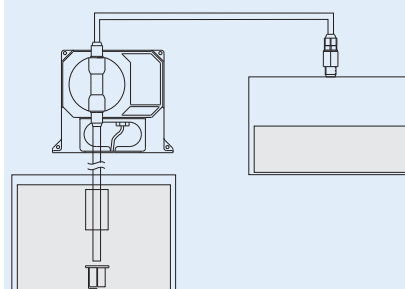

* -1 = 110/115 VAC power supply
-2 = 220/2400 VAC power supply

** Required for operation

Replacement Parts for BlackStone Chemical Dosing Pumps

Assembly Diagram

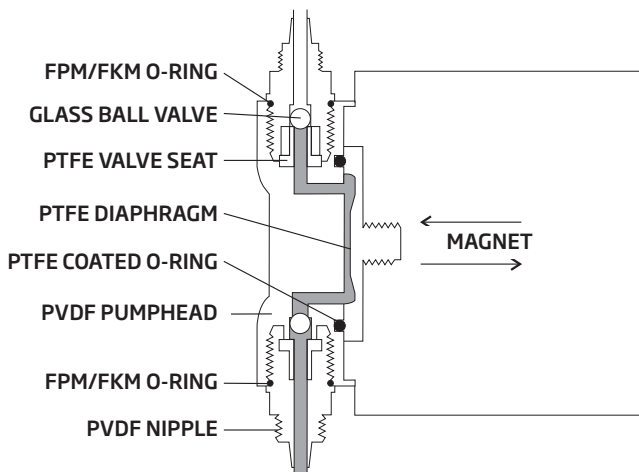
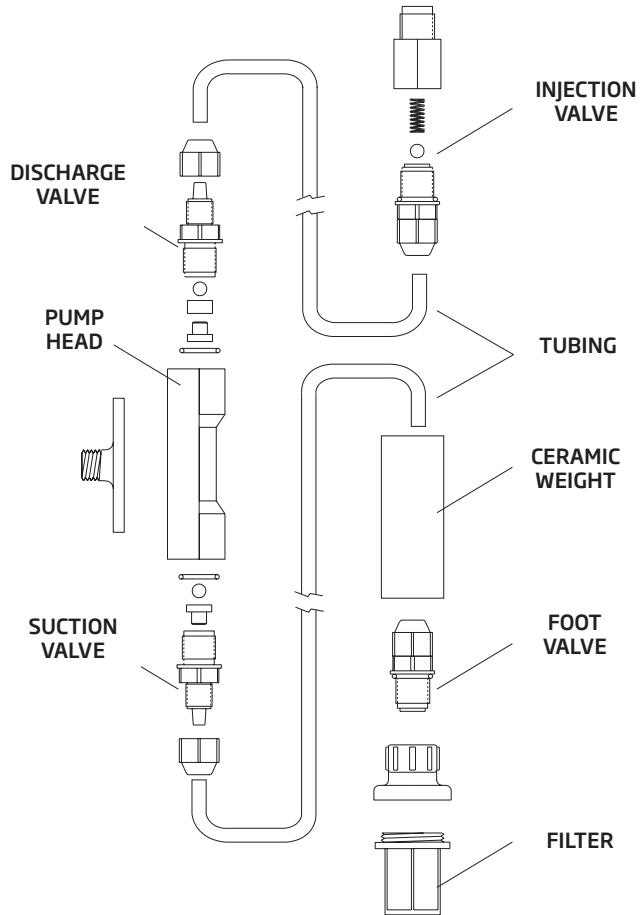

Mechanical Dimensions for BlackStone Chemical Dosing Pumps

Front View

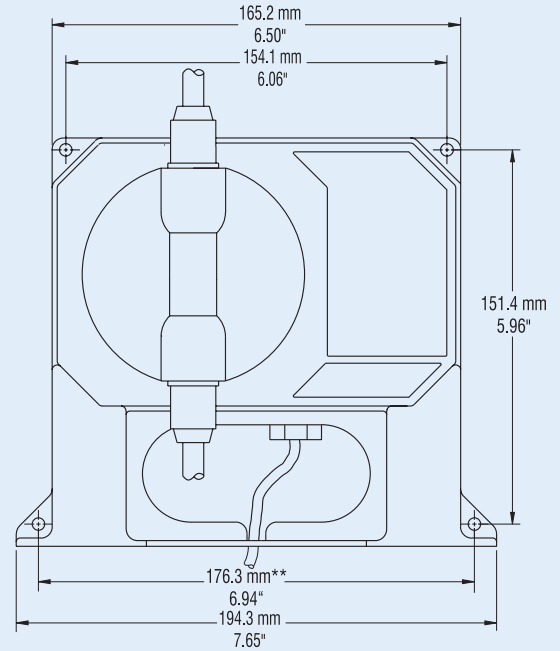

** Dimensions for floor and wall mounting

Side View

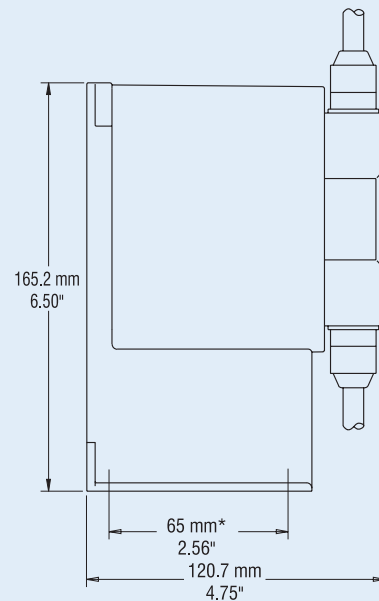

* Dimensions for floor mounting

ORDERING INFORMATION

HI 721101

This kit contains the PVDF pumphead, PTFE coated O-ring, 6 screws and washers.

HI 721102

This kit contains all the necessary replacement parts for your discharge valve assembly. Complete with a FPM/FKM O-ring, glass valve ball, the valve spacer and seat, head nipple and the tube nut to secure the assembled parts.

HI 721103

Suction valve assembly, complete with a FPM/FKM O-ring, glass valve ball, the valve spacer and seat, head nipple and the tube nut to secure the assembled parts.

HI 721004

Complete with an injection nipple, PTFE coated spring, glass valve ball and a valve assembly.

HI 721005

This kit contains a filter with a filter holder and a valve assembly.

HI 721003

This kit contains 10 glass balls and 10 valve O-rings.

HI 721006

This kit contains 4 PVDF springs.

HI 720029

LDPE hose, 3 m (9.9').
 Inside diameter 4.71 mm
 Outside diameter 7.87 mm

HI 720030

LDPE hose, 10 m (33').
 Inside diameter 4.71 mm
 Outside diameter 7.87 mm

HI 720031

LDPE hose, 50 m (165').
 Inside diameter 4.71 mm
 Outside diameter 7.87 mm

HI 720032

LDPE hose, 100 m (333').
 Inside diameter 4.71 mm
 Outside diameter 7.87 mm

HI 721008

This kit contains 4 ceramic weights.

HI 740156

This kit contains 3 valve seats.

HI 721101

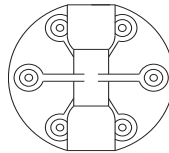

pumphead

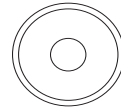

PTFE coated o-ring

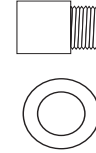

6 screws and washers

HI 721102

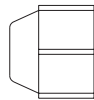

tube nut

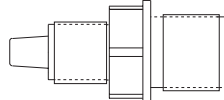

head nipple



valve

spacer



o-ring



valve seat

HI 721103



o-ring

valve



valve seat

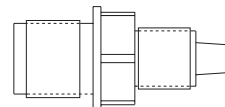

head nipple

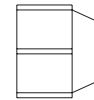

tube nut

HI 721004

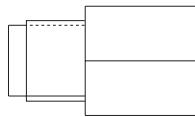

injection nipple



PVDF spring

valve

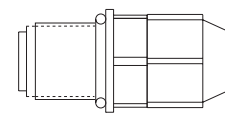

valve assembly

HI 721005

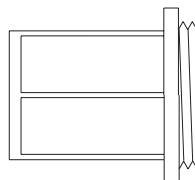

filter

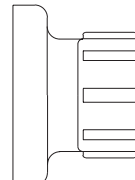

filter holder

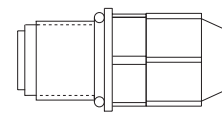

valve assembly

HI 721003



o-ring



valve

HI 721006



PVDF spring

HI 720032

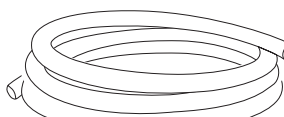

LDPE hose

HI 721008

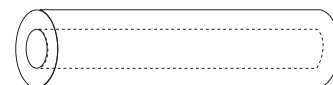

ceramic weight